

ITEM NO.	QTY.	PART NUMBER	DESCRIPTION
1	1	CC0011	CHOKE NIPPLE, 2"1502 H2S 15M PSL3
2	1	CC0013	CHOKE INDICATOR, 3/4" (FOR 2"CHOKE)
3	1	CC0014	HANDWHEEL, 2" ADJUSTABLE
4	1	CC0016	BONNET, 2" 1502 OCT. CHOKE
5	1	CC0018	CHOKE BODY, 2"1502 H2S 10M
6	1	CC0022	CHOKE STEM, 3/4" H2S 15M LONG
7	1	CC0028	CHOKE PACKING, 2"
8	1	CC0029	CHOKE STEM GUIDE, 2" CHOKE
9	1	CC0030	CHOKE PACKING RETAINER, 2" CHOKE
10	1	CC0037	CHOKE SEAT, 3/4" FC-140 6"LINED CARBIDE
11	1	CC0044	SNAP RING, 2" CHOKE BONNET
12	1	CC0278	BONNET EXTENSION, 2" MSI MANUAL
13	1	CC0281	BONNET THREAD BUSHING, 2" CHOKE
14	1	HC0012	HEX NUT, 5/8-11
15	1	HC0013	THUMB SCREW, 3/8"-16 x 1.25" (NYLON TIPPED)
16	1	HC0014	FLAT WASHER, 5/8" STD
17	2	HC0176	SOC HD, 1/4"-20 x 2.25"
18	1	HC0177	BALL, 5/16" BRASS CDA270 GRADE 200
19	1	HC0199	GREASE FITTING, 1/4"NPT ALEMITE
20	1	HC0237	BANDING, F-CLAMP OPEN END 5/8"WIDE x 2.50"ID
21	2	UC0003	NUT RETAINER SET, 2"1502
22	2	UC0004	SPIRAL RETAINER RING, 2"1502
23	3	UC0012	RESILIENT SEAL, 2"1502 H2S (HSN)
24	3	UC0131	WINGNUT, 2"1502 H2S
25	1	VC0571	NAME TAG - FITTINGS/FLOWLINE (BANDED)

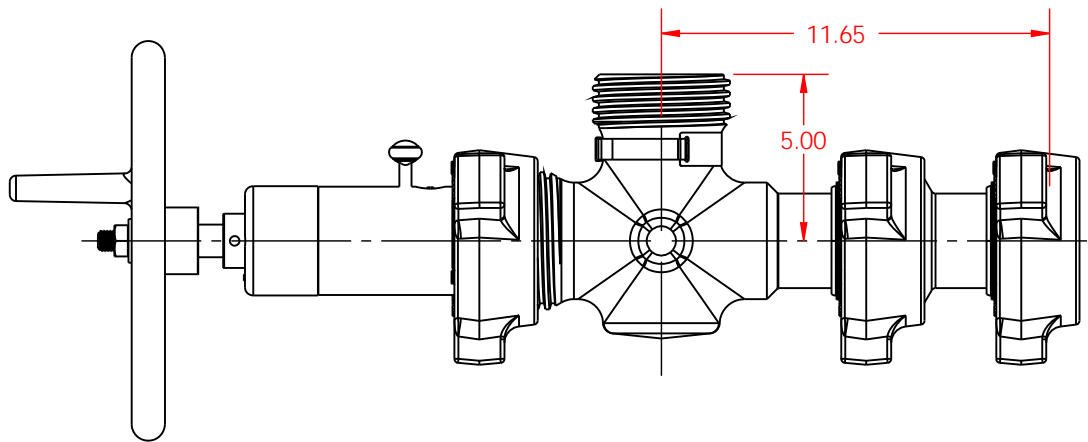

THIS DRAWING IS THE PROPERTY OF DIXIE IRON WORKS, LTD. THE BORROWER AGREES BY RECEIVING THE DRAWING TO RETURN IT UPON REQUEST AND TO NEITHER REPRODUCE COPY OR FURNISH INFORMATION FROM IT TO OTHERS WITHOUT EXPRESSED WRITTEN PERMISSION OF DIXIE IRON WORKS, LTD. ALL ARTICLES MANUFACTURED IN ACCORDANCE WITH THIS DRAWING SHALL BE CONSIDERED DESIGNS OF DIXIE IRON WORKS, LTD. AND MAY NOT BE USED OR SOLD WITHOUT DIXIE IRON WORKS, LTD. WRITTEN PERMISSION.

NOTES  
 1. BREAK ALL EDGES 0.008/0.016 x 45° OR R0.008/0.016 EXCEPT THREADS.  
 2. ALL MACHINED CORNER RADII TO BE R0.031.  
 3. ALL DIMENSIONS ARE IN INCHES (UNLESS OTHERWISE STATED).  
 4. BLUNT START ALL ACME THREADS.  
 5. ALL DRILLERS TO BE CONCENTRIC WITHIN 0.005" (UNLESS OTHERWISE STATED).  
 6. MACHINED SURFACES TO BE 325µm Ra (UNLESS OTHERWISE STATED).  
 7. ALL DIMENSIONS IN PARENTHESIS ARE REFERENCE DIMENSIONS (ØXXX).  
 8. 'Q' DENOTES SYMMETRY BETWEEN FEATURES, ABOUT 'Q' AXIS, UNLESS NOTED OTHERWISE.

UNSPECIFIED TOLERANCES	REVISION	CHANGE MADE	ECN NUMBER	DESCRIPTION
FRACTIONS ±1/64 DECIMALS .XX ±0.010 XXX ±0.005 XXXX ±0.001 ANGLE ±1/2°	0			ADJ CHOKE, 2"1502FM H2S 10M 3/4"MAX
DATUM INDICATING SYMBOL	CONCENTRICITY	ANGULARITY	RUNOUT	COUNTERBORE
POSITION	FLATNESS	PERPENDICULARITY	PARALLELISM	COUNTERSINK

MATERIAL/HEAT TREAT/ WELD PROCEDURE H2S SERVICE 10,000 PSI WORKING PRESSURE		DRAWN BY HAHII
WEIGHT 106.601 lbs.		DATE 9/8/05
SHEET SHEET 1 OF 1	PART NUMBER CA0020	

300 West Main Street  
Alice, TX 78332  
www.dlwmisi.com  
800.242.0059  
MSI is a division of Dixie Iron Works, Ltd.