

ITEM NO.	QTY.	PART NUMBER	DESCRIPTION
1	1	CC0011	CHOKE NIPPLE, 2"1502 H2S 10M
2	1	CC0018	CHOKE BODY, 2"1502 H2S 10M
3	1	UC0001	CHOKE CAP, 2" 1502M H2S 15M
4	2	UC0003	NUT RETAINER SET, 2"1502
5	3	UC0004	SPIRAL RETAINER RING, 2"1502
6	3	UC0012	RESILIENT SEAL, 2"1502 H2S (HNBR)
7	3	UC0131	WINGNUT, 2"1502 H2S

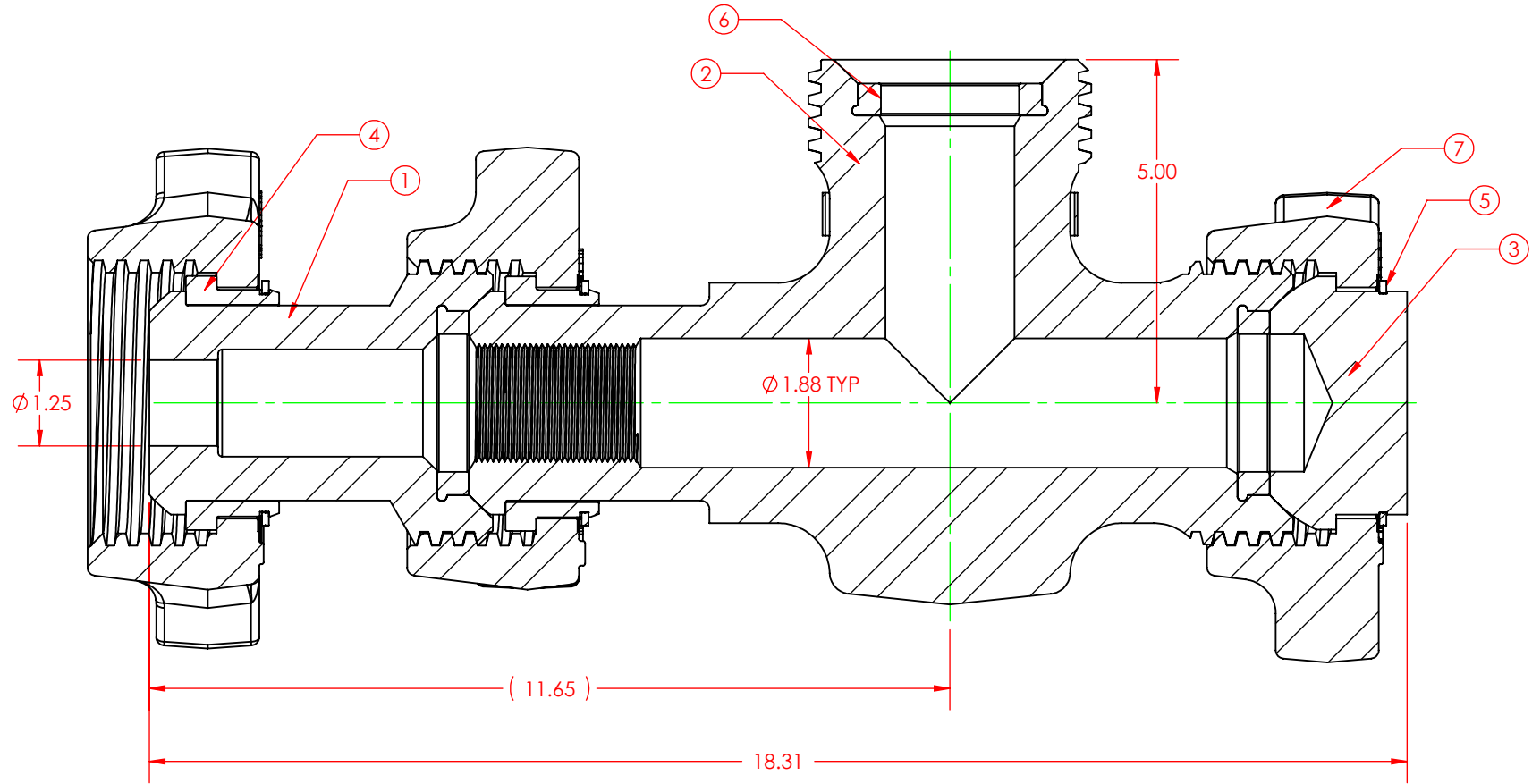

<p>THIS DRAWING IS THE PROPERTY OF DIXIE IRON WORKS, LTD. THE BORROWER AGREES BY RECEIVING THE DRAWING TO RETURN IT UPON REQUEST AND TO NEITHER REPRODUCE COPY OR FURNISH INFORMATION FROM IT TO OTHERS WITHOUT EXPRESSED WRITTEN PERMISSION OF DIXIE IRON WORKS, LTD. ALL ARTICLES MANUFACTURED IN ACCORDANCE WITH THIS DRAWING SHALL BE CONSIDERED DESIGNS OF DIXIE IRON WORKS, LTD. AND MAY NOT BE USED OR SOLD WITHOUT DIXIE IRON WORKS, LTD. WRITTEN PERMISSION.</p>	CHANGE MADE	ECN NUMBER	DESCRIPTION POS CHOKE, 2"1502FM H2S 10M	
			MATERIAL/ HEAT TREAT/ WELD PROCEDURE H2S SERVICE 10,000 WORKING PRESSURE	DRAWN BY RSE
			DATE 05/13/10	300 West Main Street Alice, TX 78332 www.diwmsi.com 800.242.0059 MSI is a division of Dixie Iron Works, Ltd.
			WEIGHT 75 lbs.	SHEET SHEET 1 OF 1



300 West Main Street
Alice, TX 78332
www.diwmsi.com
800.242.0059
MSI is a division of Dixie Iron Works, Ltd.



REV
0