

B1

ITEM NO.	QTY.	PART NUMBER	DESCRIPTION
1	1	AA0036	HYD CYLINDER, DOUBLE ACTING 3.25" (2"STROKE)
2	1	CC0028	CHOKE PACKING, 2"
3	1	CC0029	CHOKE STEM GUIDE, 2" CHOKE
4	1	CC0030	CHOKE PACKING RETAINER, 2" CHOKE
5	1	CC0044	SNAP RING, 2" CHOKE BONNET
6	1	CC0230	BONNET, 2" H2S 15M MSI FOR HYD 2"1502
7	1	CC0231	BONNET FLANGE, 2" 15M MSI FOR HYD
8	4	CC0233	BONNET STAY BOLT, 2" 15M MSI FOR HYD
9	1	CC0236	STEM BUSHING, 2" 15M MSI FOR HYD
10	1	CC0274	SEAL, HYDRAULIC CHOKE STEM
11	1	CC0275	ROD SEAL RETAINER, 2" 15M HYDRAULIC ACTUATOR
12	1	CC0336	CHOKE STEM, 3/4"-1" H2S 15M FOR MSI HYD (LONG)
13	9	HC0012	HEX NUT, 5/8"-11 HEAVY HEX 2H
14	2	HC0015	HEX HD, 3/8"-16 x 1.00"
15	4	HC0124	HEX HD, 1/4"-20 x 0.50"
16	1	HC0199	GREASE FITTING, 1/4"NPT ALEMITE
17	9	HC0209	LOCK WASHER, 5/8" STANDARD
18	1	UC0131	WINGNUT, 2"1502 H2S (10lbs)

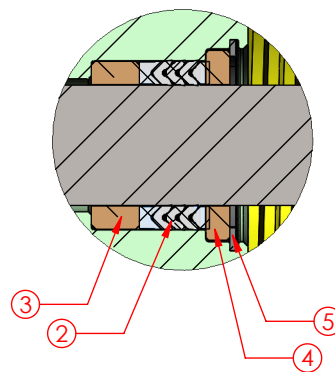
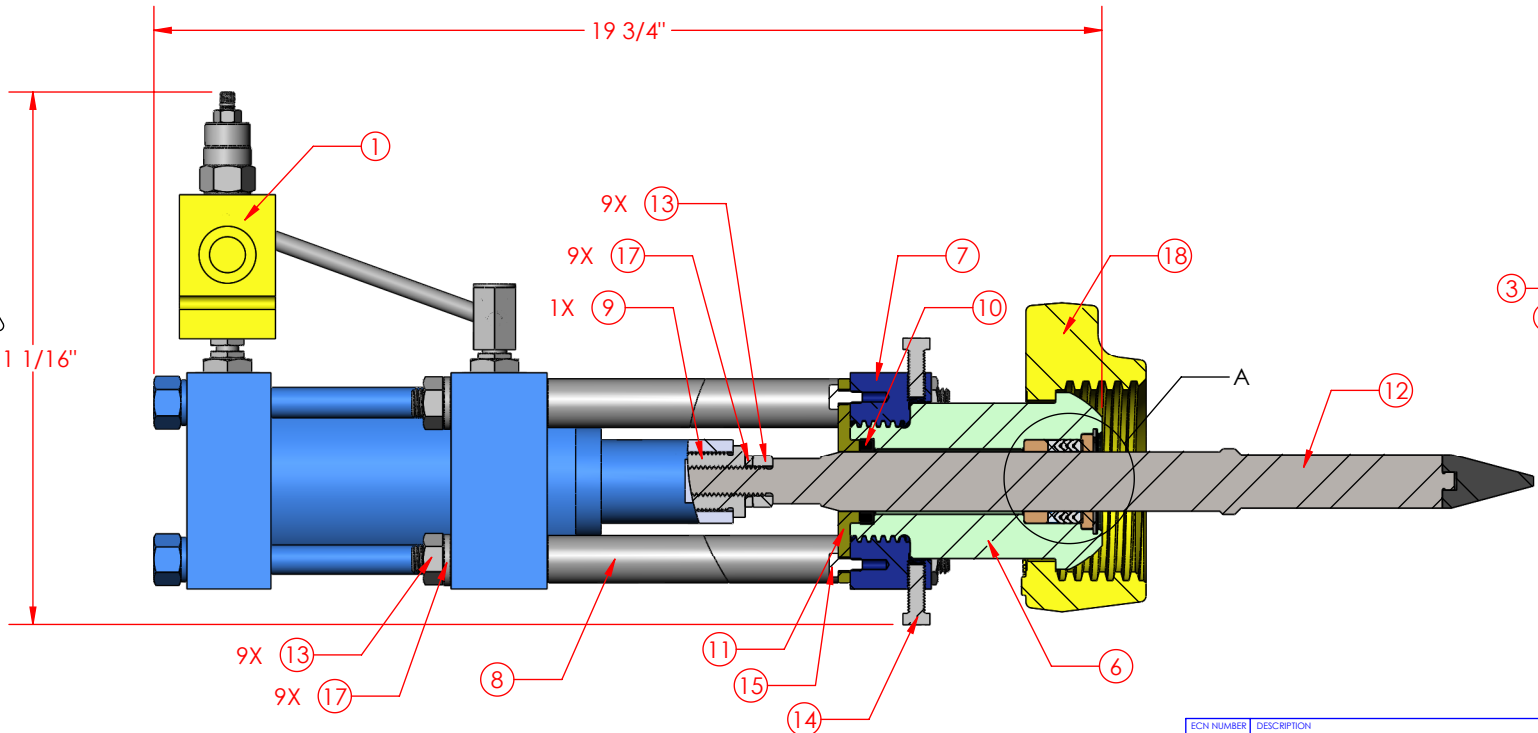

DETAIL A
PACKING ORIENTATION

B2

B4

CHANGE MADE	REVISED BY	DATE
1) REMOVED HC0048; REPLACED WITH HC0209	RSE	01/28/2014
2) ADDED DETAIL A		
3) REPOSITIONED DIMENSION		
4) UPDATED DRAWING TEMPLATE		
5)		
6)		
7)		
8)		

ECN NUMBER	DESCRIPTION
5002	BONNET ASSY, 2"1502M 15M 3/4" LONG (HYDRAULIC)
WORKING PRESSURE:	TEMPERATURE CLASS:
15,000 PSI	PU
RETAINED FLUIDS:	PR LEVEL:
BB	1
WEIGHT:	SHEET:
94 LBS.	1
	PART NUMBER:
	CA0168

300 WEST MAIN ST.
ALICE, TX 78332
www.diwmsi.com
800.242.0059
MSI IS A DIVISION OF DIXIE IRON WORKS, LTD.

THIS DRAWING IS THE PROPERTY OF DIXIE IRON WORKS, LTD. THE BORROWER AGREES BY RECEIVING THE DRAWING TO RETURN IT UPON REQUEST AND TO NEITHER REPRODUCE COPY OR FURNISH INFORMATION FROM IT TO OTHERS WITHOUT EXPRESSED WRITTEN PERMISSION OF DIXIE IRON WORKS, LTD. ALL ARTICLES MANUFACTURED IN ACCORDANCE WITH THIS DRAWING SHALL BE CONSIDERED DESIGNS OF DIXIE IRON WORKS, LTD. AND MAY NOT BE USED OR SOLD WITHOUT DIXIE IRON WORKS, LTD. WRITTEN PERMISSION.