

B1

ITEM NO.	QTY.	PART NUMBER	DESCRIPTION
1	1	AA0036	HYD CYLINDER, DOUBLE ACTING 3.25" (2"STROKE)
2	1	CC0012	CHOKE NIPPLE, 2"1502 STD 15M
3	1	CC0028	CHOKE PACKING, 2"
4	1	CC0029	CHOKE STEM GUIDE, 2" CHOKE
5	1	CC0030	CHOKE PACKING RETAINER, 2" CHOKE
6	1	CC0037	CHOKE SEAT, 3/4" FC-140 6"LINED CARBIDE
7	1	CC0043	CHOKE BODY, 2"1502 STD 15M
8	1	CC0044	SNAP RING, 2" CHOKE BONNET
9	1	CC0230	BONNET, 2" H2S 15M MSI FOR HYD 2"1502
10	1	CC0231	BONNET FLANGE, 2" 15M MSI FOR HYD
11	4	CC0233	BONNET STAY BOLT, 2" 15M MSI FOR HYD
12	1	CC0236	STEM BUSHING, 2" 15M MSI FOR HYD
13	1	CC0274	SEAL, HYDRAULIC CHOKE STEM
14	1	CC0275	ROD SEAL RETAINER, 2" 15M HYDRAULIC ACTUATOR
15	1	CC0336	CHOKE STEM, 3/4" H2S 15M FOR MSI HYD (LONG)
16	9	HC0012	HEX NUT, 5/8-11
17	2	HC0015F	HEX HD, 3/8"-16 x 1.00"
18	9	HC0048	LOCK WASHER, 5/8" HIGH COLLAR
19	4	HC0124	HEX HD, 1/4"-20 x 0.50"
20	1	HC0199	GREASE FITTING, 1/4"NPT ALEMITE
21	3	UC0002	WINGNUT, 2"1502 STD (10lbs)
22	2	UC0003	NUT RETAINER SET, 2"1502
23	2	UC0004	SPIRAL RETAINER RING, 2"1502
24	3	UC0011	RESILIENT SEAL, 2"1502 STD (BUNA)

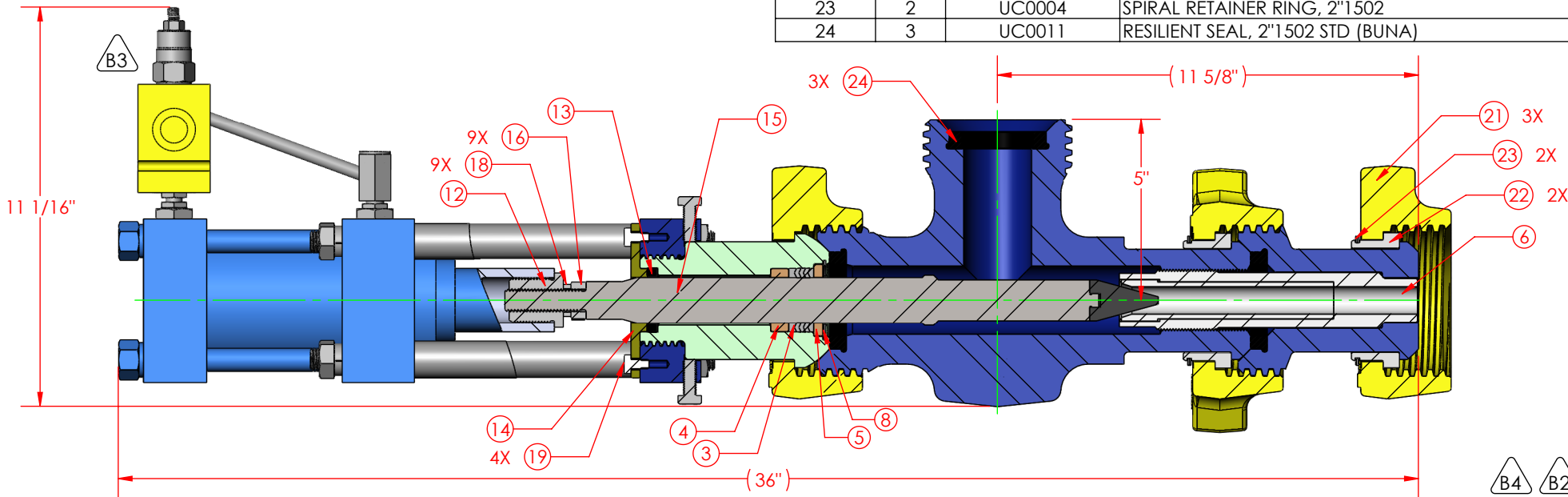

B4 B2

ECN NUMBER	DESCRIPTION
4873	ADJ CHOKE, 2"1502FM STD 15M 3/4"MAX HYDRAULIC

CHANGE MADE	REVISED BY	RSE	DATE	08/07/2013
1)	REMOVED BANDING TAG FROM BOM			
2)	DIMS WERE DECIMAL; NOW FRACTIONAL			
3)	UPDATED TO CURRENT AA0036 PART			
4)	UPDATED DRAWING TEMPLATE			
5)				
6)				
7)				
8)				

WORKING PRESSURE:	TEMPERATURE CLASS:	DRAWN BY:
15,000 PSI	PU	HAHII
RETAINED FLUIDS:	PR LEVEL:	DATE:
BB	1	10/24/02
WEIGHT:	SHEET:	PART NUMBER:
158 LBS.	SHEET 1 OF 1	CA0169



THIS DRAWING IS THE PROPERTY OF DIXIE IRON WORKS, LTD. THE BORROWER AGREES BY RECEIVING THE DRAWING TO RETURN IT UPON REQUEST AND TO NEITHER REPRODUCE COPY OR FURNISH INFORMATION FROM IT TO OTHERS WITHOUT EXPRESSED WRITTEN PERMISSION OF DIXIE IRON WORKS, LTD. ALL ARTICLES MANUFACTURED IN ACCORDANCE WITH THIS DRAWING SHALL BE CONSIDERED DESIGNS OF DIXIE IRON WORKS, LTD. AND MAY NOT BE USED OR SOLD WITHOUT DIXIE IRON WORKS, LTD. WRITTEN PERMISSION.

REV B