

ITEM NO.	QTY.	PART NUMBER	DESCRIPTION
1	1	CC0013	CHOKE INDICATOR, 3/4" (FOR 2" CHOKE)
2	1	CC0014	HANDWHEEL, 2" ADJ CHOKE "MSI"
3	1	CC0016	BONNET, 2" H2S 15M MSI MANUAL
4	1	CC0022	CHOKE STEM, 3/4"-1" MAX 15M LONG
5	1	CC0028	CHOKE PACKING, 2"
6	1	CC0029	CHOKE STEM GUIDE, 2" CHOKE
7	1	CC0030	CHOKE PACKING RETAINER, 2" CHOKE
8	1	CC0044	SNAP RING, 2" CHOKE BONNET
9	1	CC0278	BONNET EXTENSION, 2" MSI MANUAL
10	1	CC0281	BONNET THREAD BUSHING, 2" CHOKE
11	1	HC0012	HEX NUT, 5/8-11
12	1	HC0013	THUMB SCREW, 3/8"-16 x 1.50" (NYLON TIPPED)
13	1	HC0014	FLAT WASHER, 5/8" STD
14	2	HC0111	LOCK WASHER, 1/4" HIGH COLLAR
15	2	HC0176	SOC HD, 1/4"-20 x 2.25"
16	1	HC0177	BALL, 5/16" BRASS CDA270 GRADE 200
17	1	HC0199	GREASE FITTING, 1/4"NPT ALEMITE
18	1	UC0002	WINGNUT, 2"1502 STD (10lbs)

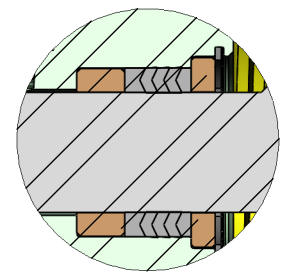
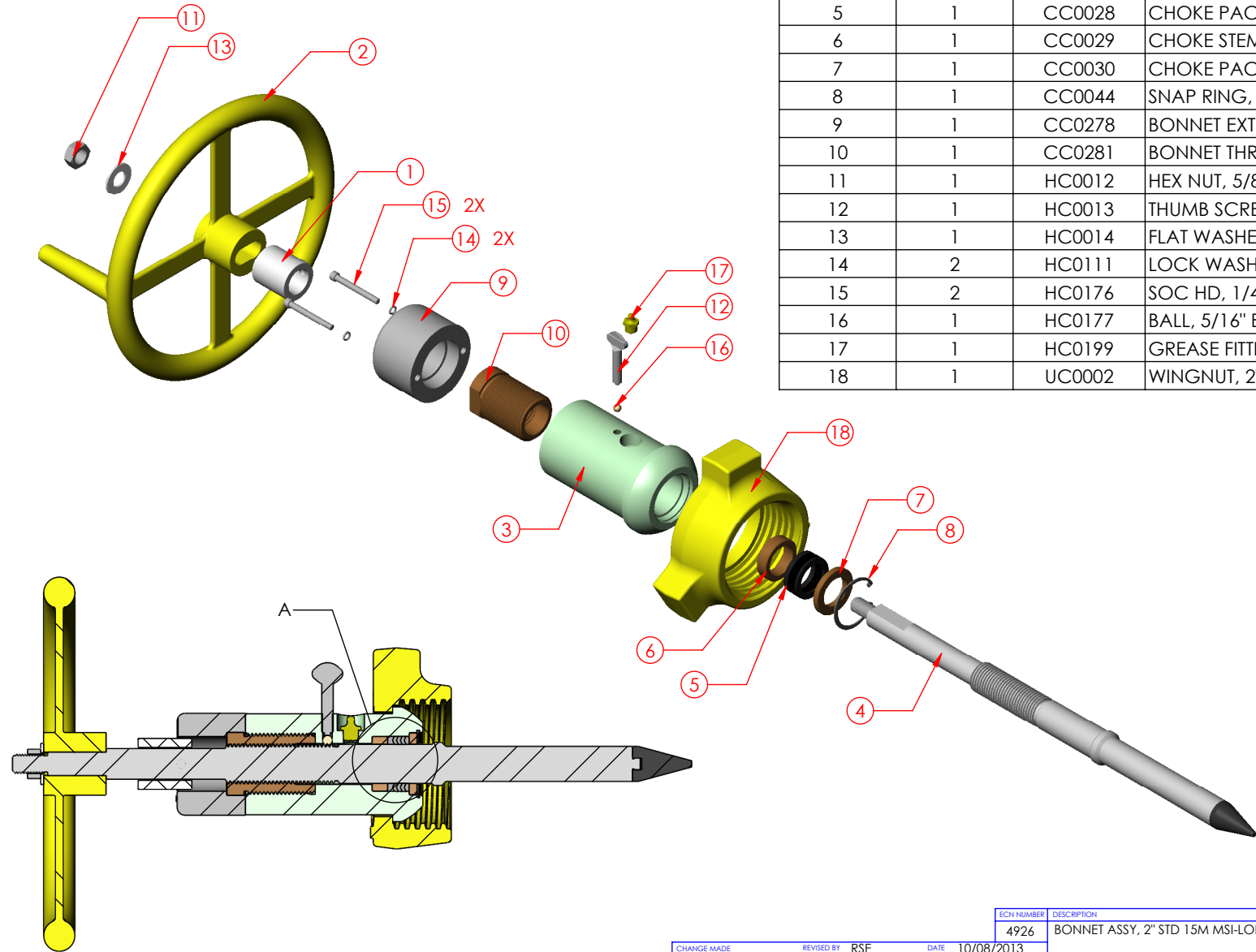

DETAIL A
PACKING ORIENTATION

A1

A2

ECN NUMBER		DESCRIPTION	
4926		BONNET ASSY, 2" STD 15M MSI-LONG STEM	
WORKING PRESSURE:	TEMPERATURE CLASS:	DRAWN BY:	
15,000 PSI	PU	RSE	
RETAINED FLUIDS:	PR LEVEL:	DATE:	
BB	1	12/06/10	
WEIGHT:	SHEET:	PART NUMBER:	REV:
41 lbs.	SHEET 1 OF 1	CA0176	A

CHANGE MADE	REVISED BY	DATE
1) ADDED DETAIL VIEW AND FLIPPED PACKING ORIENTATION TO THE CORRECT PATH 2) UPDATED DRAWING TEMPLATE	RSE	10/08/2013
3)		
4)		
5)		
6)		
7)		



THIS DRAWING IS THE PROPERTY OF DIXIE IRON WORKS, LTD. THE BORROWER AGREES BY RECEIVING THE DRAWING TO RETURN IT UPON REQUEST AND TO NEITHER REPRODUCE COPY OR FURNISH INFORMATION FROM IT TO OTHERS WITHOUT EXPRESSED WRITTEN PERMISSION OF DIXIE IRON WORKS, LTD. ALL ARTICLES MANUFACTURED IN ACCORDANCE WITH THIS DRAWING SHALL BE CONSIDERED DESIGNS OF DIXIE IRON WORKS, LTD. AND MAY NOT BE USED OR SOLD WITHOUT DIXIE IRON WORKS, LTD. WRITTEN PERMISSION.