

ITEM NO.	QTY.	PART NUMBER	DESCRIPTION
1	1	CC0008	HANDWHEEL, 3" ADJ CHOKE H2-2"MAX
2	1	CC0027	CHOKE PACKING, H2 COMPLETE (2"MAX)
3	1	CC0034	CHOKE INDICATOR, 2"MAX H2 (FOR 3"CHOKE)
4	1	CC0059	CHOKE STEM, 2"MAX TUNGSTEN CARBIDE H-2
5	1	CC0284	BONNET, 3" STD 15M H-2 (HAMMER)
6	1	CC0285	BONNET THREAD BUSHING, 3" CHOKE
7	1	CC0286	BONNET EXTENSION, 3" MSI MANUAL
8	1	HC0012	HEX NUT, 5/8"-11 HEAVY HEX 2H
9	1	HC0013	THUMB SCREW, 3/8"-16 x 1.50" (NYLON TIPPED)
10	1	HC0014	FLAT WASHER, 5/8" STD
11	2	HC0111	LOCK WASHER, 1/4" HIGH COLLAR
12	1	HC0177	BALL, 5/16" BRASS CDA270 GRADE 200
13	2	HC0203	SOC HD, 1/4"-20 x 1.50"
14	1	HC0517	GREASE FITTING, 1/8" NPT ALEMITE
15	1	OC0023	O-RING, 3" BONNET H2S (2-339)
16	1	OC0024	PAR-BACK, 3" BONNET H2S (8-339)
17	1	UC0009	WINGNUT, 3"1502 STD

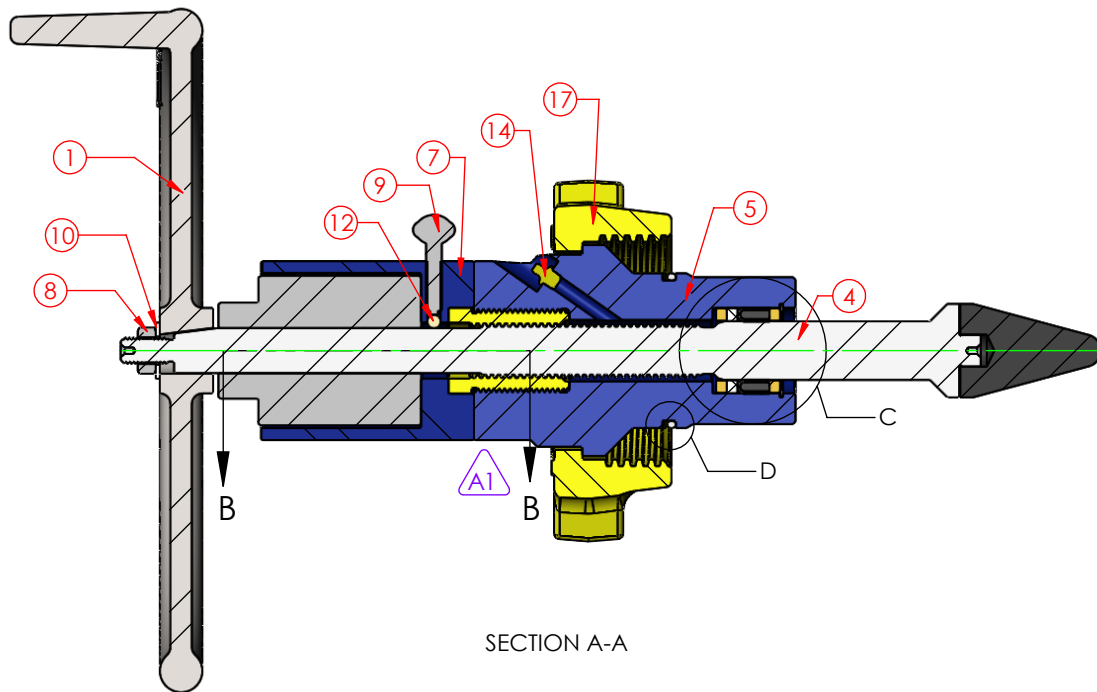

SECTION A-A

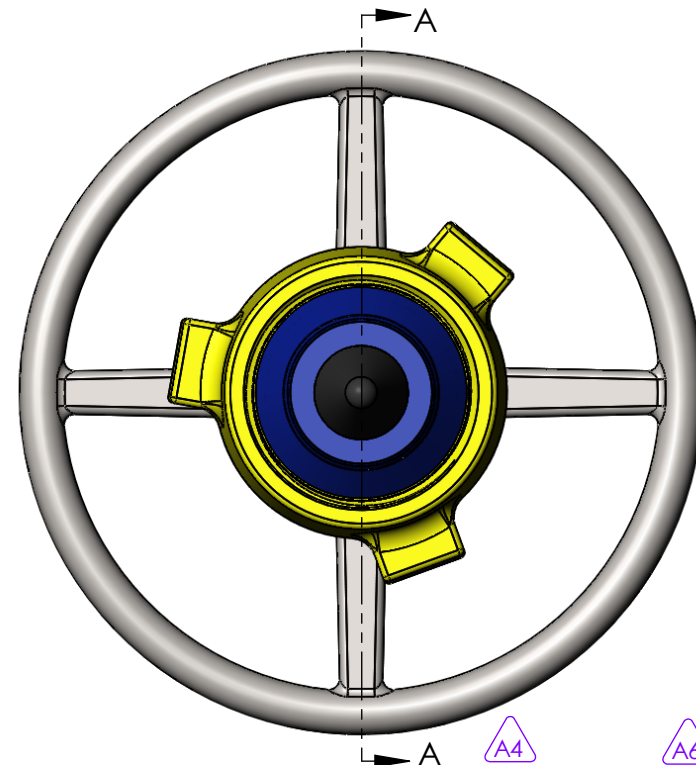

ECH NUMBER		DESCRIPTION	
5149		BONNET ASSY, 3" STD 15M H-2 (HAMMER)	
CHANGE MADE		REVISED BY	DATE
		LMS	6/30/2014
WORKING PRESSURE:	TEMPERATURE CLASS:	DRAWN BY:	
15,000 PSI	PU	RMR	
RETAINED FLUIDS:	PR LEVEL:	DATE:	
BB	1	04/11/2008	
WEIGHT:	SHEET:	PART NUMBER:	REV:
71 LBS.	SHEET 1 OF 2	CA0180	A

- 1) UPDATED CC0284 WITH GREASE FITTING HOLE
- 2) ADDED HC0517 (GREASE FITTING)
- 3) REMOVED BANDING TAG
- 4) ADDED PARENT VIEW
- 5) ADDED PAGE 2
- 6) UPDATED SHEET TEMPLATE
- 7)
- 8)



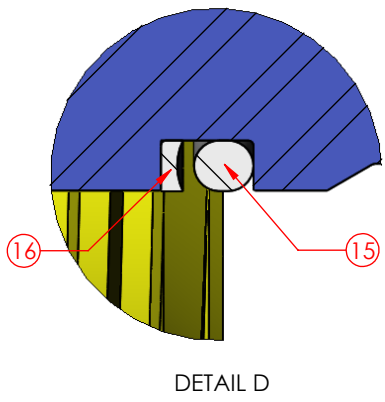
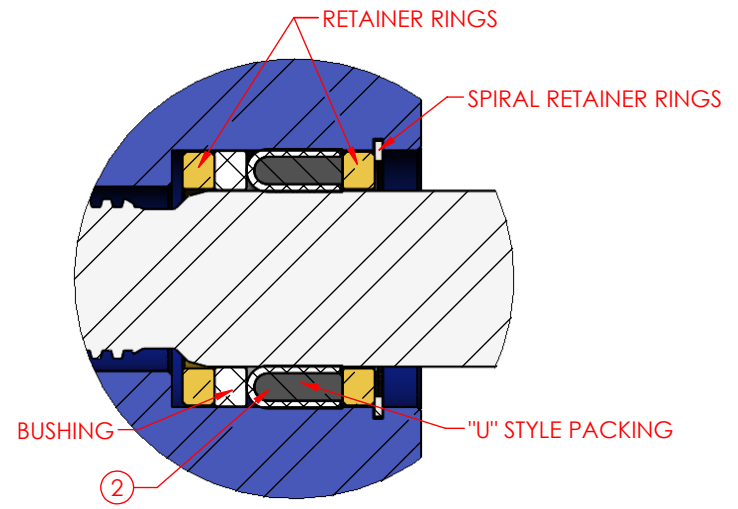
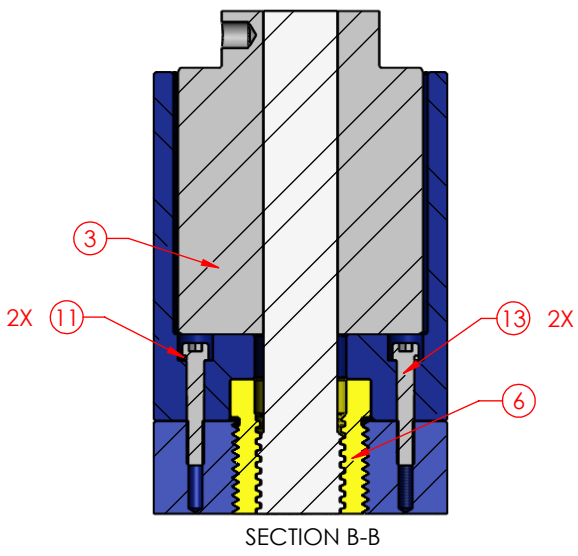

ECN NUMBER	DESCRIPTION		
5149	BONNET ASSY, 3" STD 15M H-2 (HAMMER)		
WORKING PRESSURE:	TEMPERATURE CLASS:	DRAWN BY:	
15,000 PSI	PU	RMR	
RETAINED FLUIDS:	PR LEVEL:	DATE:	
BB	1	04/11/2008	
WEIGHT:	SHEET:	PART NUMBER:	REV:
71 LBS.	SHEET 2 OF 2	CA0180	A

CHANGE MADE	REVISED BY	LMS	DATE	6/30/2014
1) UPDATED CC0284 WITH GREASE FITTING HOLE				
2) ADDED HC0517 (GREASE FITTING)				
3) REMOVED BANDING TAG				
4) ADDED PARENT VIEW				
5) ADDED PAGE 2				
6) UPDATED SHEET TEMPLATE				
7)				
8)				

  
 300 WEST MAIN ST.  
 ALICE, TX 78332  
 www.diwmsi.com  
 800.242.0059  
MSI IS A DIVISION OF DIXIE IRON WORKS, LTD.

THIS DRAWING IS THE PROPERTY OF DIXIE IRON WORKS, LTD. THE BORROWER AGREES BY RECEIVING THE DRAWING TO RETURN IT UPON REQUEST AND TO NEITHER REPRODUCE COPY OR FURNISH INFORMATION FROM IT TO OTHERS WITHOUT EXPRESSED WRITTEN PERMISSION OF DIXIE IRON WORKS, LTD. ALL ARTICLES MANUFACTURED IN ACCORDANCE WITH THIS DRAWING SHALL BE CONSIDERED DESIGNS OF DIXIE IRON WORKS, LTD. AND MAY NOT BE USED OR SOLD WITHOUT DIXIE IRON WORKS, LTD. WRITTEN PERMISSION.