

ITEM NO.	QTY.	PART NUMBER	DESCRIPTION
1	1	AA0036	HYD CYLINDER, DOUBLE ACTING 3.25" (2"STROKE)
2	1	AA0048-1	INDICATOR BRACKET PART, UPPER MOUNT
3	1	AA0048-2	INDICATOR BRACKET PART, LOWER MOUNT
4	1	AA0048-3	INDICATOR BRACKET PART, COVER
5	1	AA0048-4	INDICATOR BRACKET PART, INDICATOR ARM
6	1	AA0049	MINI POSITION TRANSDUCER, D61
7	1	AA0050	POSITION INDICATOR, HDI 2200 BATTERY POWERED
8	1	AA0051	CABLE ASSY, 100' INLINE FOR HDI 220 POSITION INDICATOR
9	1	CC0011	CHOKE NIPPLE, 2"1502 H2S 10M
10	1	CC0018	CHOKE BODY, 2"1502 H2S 10M
11	1	CC0028	CHOKE PACKING, 2"
12	1	CC0029	CHOKE STEM GUIDE, 2" CHOKE
13	1	CC0030	CHOKE PACKING RETAINER, 2" CHOKE
14	1	CC0044	SNAP RING, 2" CHOKE BONNET
15	1	CC0196	CHOKE SEAT, 1" FC-140 6"LINED CARBIDE
16	1	CC0230	BONNET, 2" H2S 15M MSI FOR HYD 2"1502
17	1	CC0231	BONNET FLANGE, 2" 15M MSI FOR HYD
18	4	CC0233	BONNET STAY BOLT, 2" 15M MSI FOR HYD
19	1	CC0236	STEM BUSHING, 2" 15M MSI FOR HYD
20	1	CC0274	SEAL, HYDRAULIC CHOKE STEM
21	1	CC0275	ROD SEAL RETAINER, 2" 15M HYDRAULIC ACTUATOR
22	1	CC0336	CHOKE STEM, 3/4" H2S 15M FOR MSI HYD (LONG)
23	9	HC0012	HEX NUT, 5/8-11
24	2	HC0015F	HEX HD, 3/8"-16 x 1.00"
25	9	HC0048	LOCK WASHER, 5/8" HIGH COLLAR
26	4	HC0124	HEX HD, 1/4"-20 x 0.50"
27	1	HC0199	GREASE FITTING, 1/4"NPT ALEMITE
28	4	HC0231	MACHINE SCREW, #10-32 x 1/2" STAINLESS w/WASHER
29	1	HC0233	EYE BOLT, #6-32 x 3/4 WITH 1/4 EYE, ZINC-PLATED w/NUT
30	3	HC0824	HEX NUT, 6-32, 5/16" WIDTH, 1/8" HEIGHT, w/NYLON INSRT
31	2	HC0825	MACHINE SCREW, #6-32 x 7/16" ROUND HEAD, SLOTTED, ZINC
32	2	UC0003	NUT RETAINER SET, 2"1502
33	2	UC0004	SPIRAL RETAINER RING, 2"1502
34	3	UC0012	RESILIENT SEAL, 2"1502 H2S (HNBR)
35	3	UC0131	WINGNUT, 2"1502 H2S (10lbs)

Ecn NUMBER		DESCRIPTION	
		ADJ CHOKE, 2"1502FM H2S 10M 1"MAX (HYDRAULIC)	
WORKING PRESSURE:	TEMPERATURE CLASS:	DRAWN BY:	
10,000 PSI	LU	RSE	
RETAINED FLUIDS:	PR LEVEL:	DATE:	
EE-.05	1	02/14/2013	
WEIGHT:	SHEET:	PART NUMBER:	REV:
224 lbs.	SHEET 1 OF 3	CA0237	0



300 WEST MAIN ST.
ALICE, TX 78332

www.diwmsi.com
800.242.0059

MSI IS A DIVISION OF DIXIE IRON WORKS, LTD.

THIS DRAWING IS THE PROPERTY OF DIXIE IRON WORKS, LTD. THE BORROWER AGREES BY RECEIVING THE DRAWING TO RETURN IT UPON REQUEST AND TO NEITHER REPRODUCE COPY OR FURNISH INFORMATION FROM IT TO OTHERS WITHOUT EXPRESSED WRITTEN PERMISSION OF DIXIE IRON WORKS, LTD. ALL ARTICLES MANUFACTURED IN ACCORDANCE WITH THIS DRAWING SHALL BE CONSIDERED DESIGNS OF DIXIE IRON WORKS, LTD. AND MAY NOT BE USED OR SOLD WITHOUT DIXIE IRON WORKS, LTD. WRITTEN PERMISSION.

CHANGE MADE	REVISED BY	DATE
1)		
2)		
3)		
4)		
5)		
6)		
7)		
8)		

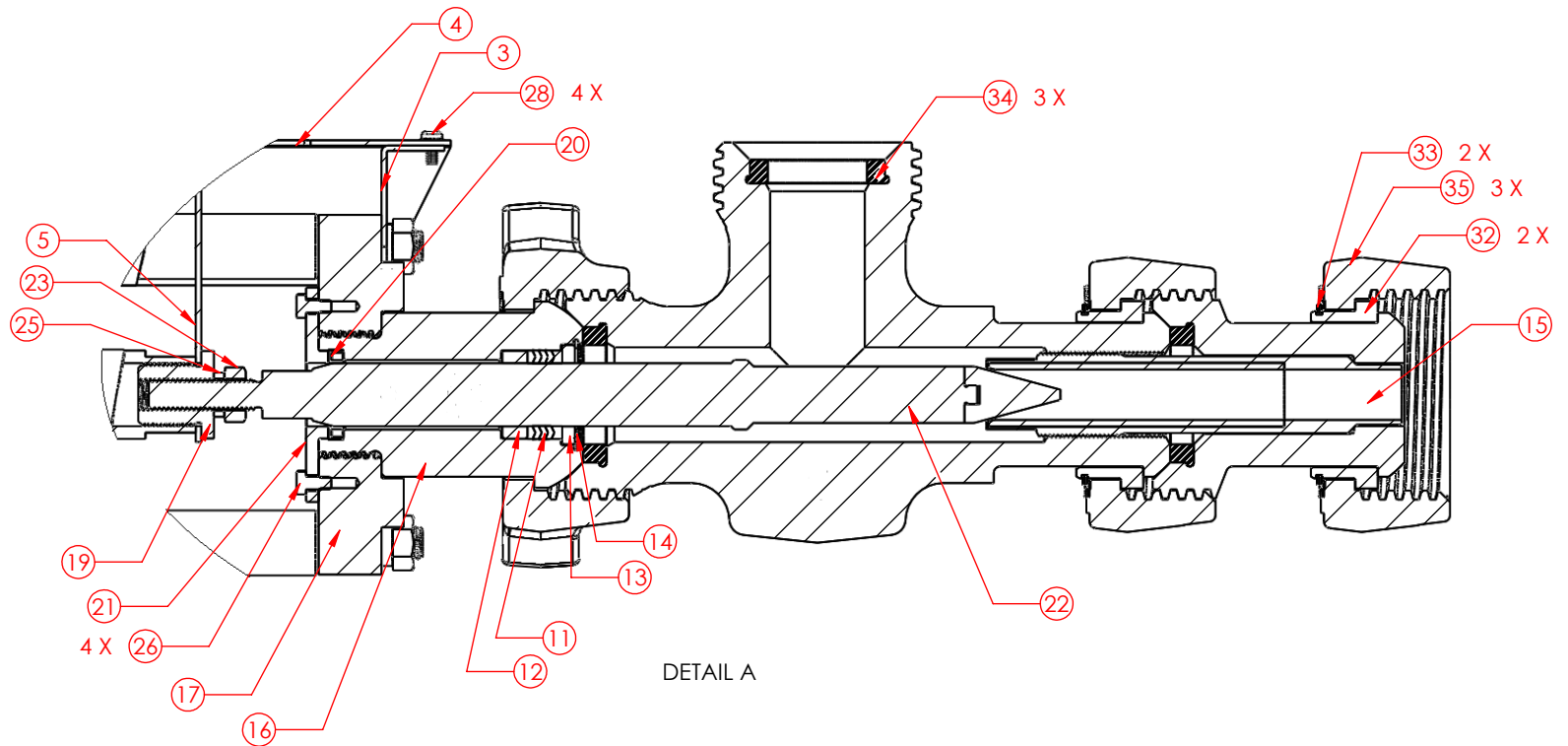

DETAIL A

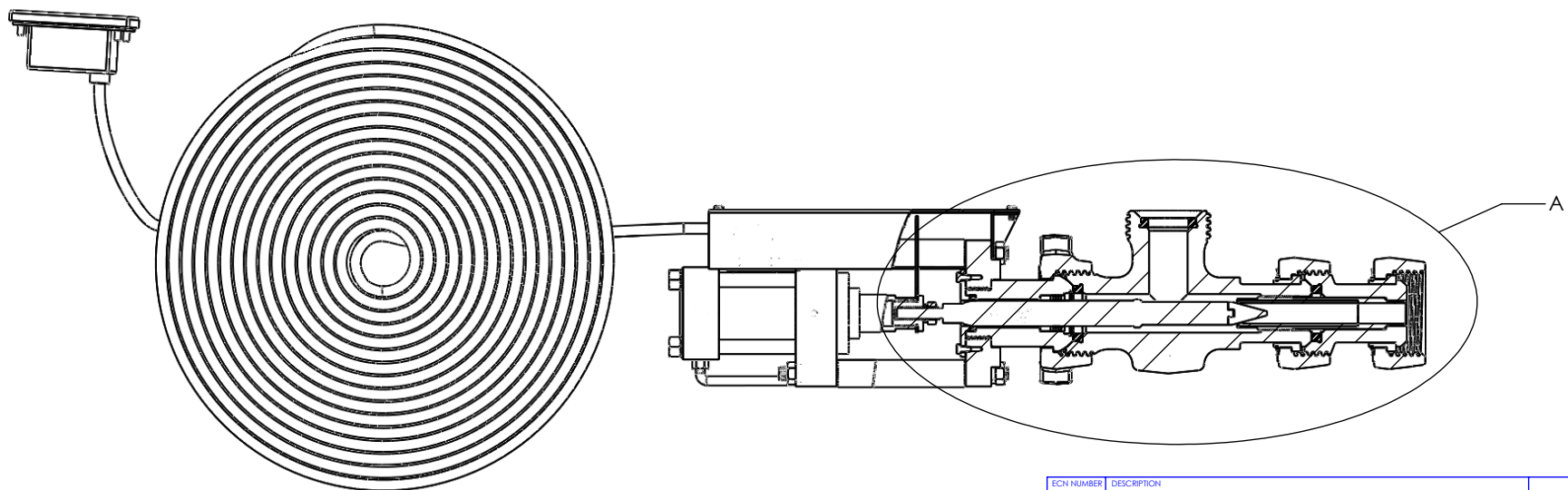

E/CN NUMBER		DESCRIPTION	
		ADJ CHOKE, 2"1502FM H2S 10M 1"MAX (HYDRAULIC)	
WORKING PRESSURE:	TEMPERATURE CLASS:	DRAWN BY:	
10,000 PSI	LU	RSE	
RETAINED FLUIDS:	PR LEVEL:	DATE:	
EE-.05	1	02/14/2013	
WEIGHT:	SHEET:	PART NUMBER:	
224 lbs.	SHEET 2 OF 3	CA0237	

CHANGE MADE	REVISED BY	DATE
1)		
2)		
3)		
4)		
5)		
6)		
7)		
8)		

300 WEST MAIN ST.
ALICE, TX 78332
www.diwmsi.com
800.242.0059
MSI IS A DIVISION OF DIXIE IRON WORKS, LTD.

THIS DRAWING IS THE PROPERTY OF DIXIE IRON WORKS, LTD. THE BORROWER AGREES BY RECEIVING THE DRAWING TO RETURN IT UPON REQUEST AND TO NEITHER REPRODUCE COPY OR FURNISH INFORMATION FROM IT TO OTHERS WITHOUT EXPRESSED WRITTEN PERMISSION OF DIXIE IRON WORKS, LTD. ALL ARTICLES MANUFACTURED IN ACCORDANCE WITH THIS DRAWING SHALL BE CONSIDERED DESIGNS OF DIXIE IRON WORKS, LTD. AND MAY NOT BE USED OR SOLD WITHOUT DIXIE IRON WORKS, LTD. WRITTEN PERMISSION.

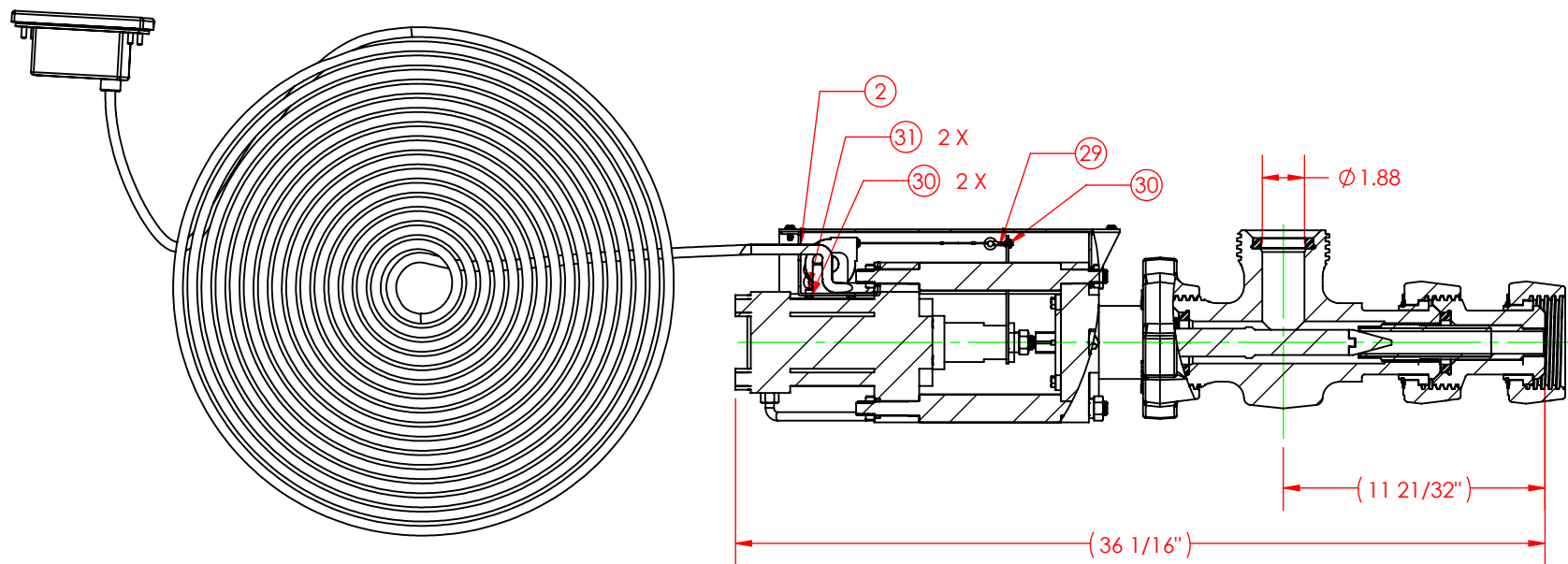
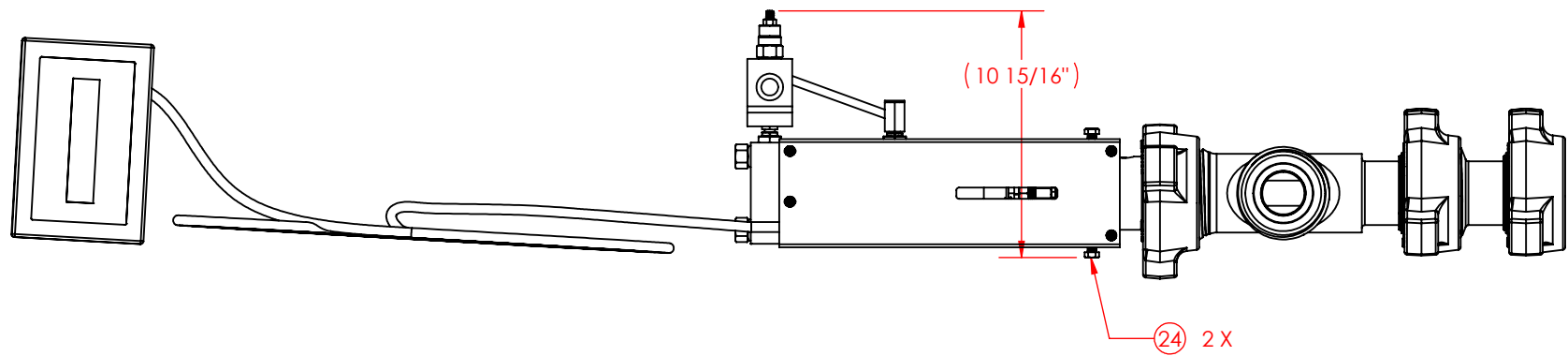

ECN NUMBER	DESCRIPTION		
	ADJ CHOKE, 2"1502FM H2S 10M 1"MAX (HYDRAULIC)		
WORKING PRESSURE:	TEMPERATURE CLASS:	DRAWN BY:	
10,000 PSI	LU	RSE	
RETAINED FLUIDS:	PR LEVEL:	DATE:	
EE-.05	1	02/14/2013	
WEIGHT:	SHEET:	PART NUMBER:	
224 lbs.	SHEET 3 OF 3	CA0237	

CHANGE MADE	REVISED BY	DATE
1)		
2)		
3)		
4)		
5)		
6)		
7)		
8)		



THIS DRAWING IS THE PROPERTY OF DIXIE IRON WORKS, LTD. THE BORROWER AGREES BY RECEIVING THE DRAWING TO RETURN IT UPON REQUEST AND TO NEITHER REPRODUCE COPY OR FURNISH INFORMATION FROM IT TO OTHERS WITHOUT EXPRESSED WRITTEN PERMISSION OF DIXIE IRON WORKS, LTD. ALL ARTICLES MANUFACTURED IN ACCORDANCE WITH THIS DRAWING SHALL BE CONSIDERED DESIGNS OF DIXIE IRON WORKS, LTD. AND MAY NOT BE USED OR SOLD WITHOUT DIXIE IRON WORKS, LTD. WRITTEN PERMISSION.