

ITEM NO.	QTY.	PART NUMBER	DESCRIPTION
1	24	HC0852	SPRING, BELLEVILLE, 1.75 X 0.88 X 0.131
2	1	HC0914	WIRE ROPE, PRESSURE SETTING TAG
3	1	HC0915	COMPRESSION SLEEVE, WIRE ROPE
4	1	HC0916	TAG, PRESSURE SETTING
5	1	HC0923	SPRING, SINGLE TURN WAVE, 2.25 X 1.93 X 38#
6	1	OC0162	O-RING, (2-126 BUNA 90)
7	1	OC0163	RV PLUNGER SEAL, 2" STD (BUNA)
8	1	OC0164	O-RING, (2-134 BUNA 90)
9	1	OC0173	O-RING, (2-227 BUNA 90)
10	1	RVC0002	RV SEAT, 1-3/8" BALL
11	1	RVC0003	RV CAGE, 2"
12	1	RVC0004	RV BALL, 1-3/8" DIAMETER
13	1	RVC0005	RV PLUNGER, 2"
14	1	RVC0006	RV BONNET, 2"
15	1	RVC0007	RV BONNET, JAM NUT, 2"
16	1	RVC0008	RV LOCK NUT, ADJUSTMENT SCREW, 2"
17	1	RVC0009	RV ADJUSTMENT SCREW, 2"
18	1	RVC0010	RV LOCK AND TAG SLEEVE, 2"
19	1	RVC0012	RV BODY, 1"1502 FM STD 15M
20	1	UC0135	WINGNUT, 1"1502 STD
21	1	UC0136	NUT RETAINER SET, 1"1502
22	1	UC0225	RESILIENT SEAL, 1" UNION STD (BUNA)
23	1	UC0277	SPIRAL RETAINER RING, 1"1502

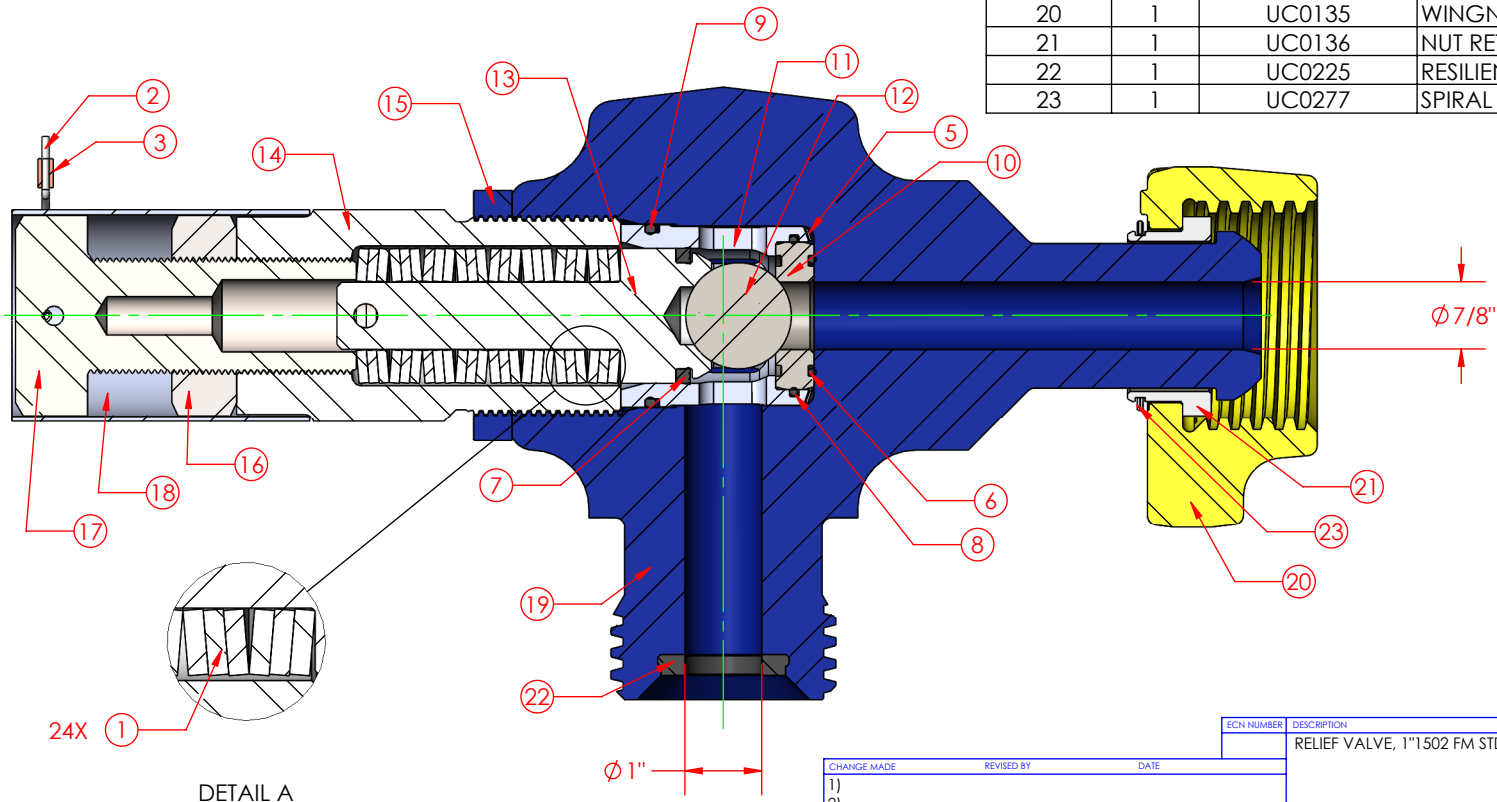

DETAIL A

CHANGE MADE		REVISED BY	DATE
1)			
2)			
3)			
4)			
5)			
6)			
7)			
8)			

ECH NUMBER		DESCRIPTION	
		RELIEF VALVE, 1"1502 FM STD 15M	
WORKING PRESSURE:	TEMPERATURE CLASS:	DRAWN BY:	
15,000 PSI	PU	RSE	
RETAINED FLUIDS:	PR LEVEL:	DATE:	
BB	1	03/17/2015	
WEIGHT:	SHEET:	PART NUMBER:	REV:
41 lbs.	SHEET 1 OF 1	RVA0003	0

300 WEST MAIN ST.
ALICE, TX 78332

www.diwmsi.com
800.242.0059

MSI IS A DIVISION OF DIXIE IRON WORKS, LTD.

THIS DRAWING IS THE PROPERTY OF DIXIE IRON WORKS, LTD. THE BORROWER AGREES BY RECEIVING THE DRAWING TO RETURN IT UPON REQUEST AND TO NEITHER REPRODUCE COPY OR FURNISH INFORMATION FROM IT TO OTHERS WITHOUT EXPRESSED WRITTEN PERMISSION OF DIXIE IRON WORKS, LTD. ALL ARTICLES MANUFACTURED IN ACCORDANCE WITH THIS DRAWING SHALL BE CONSIDERED DESIGNS OF DIXIE IRON WORKS, LTD. AND MAY NOT BE USED OR SOLD WITHOUT DIXIE IRON WORKS, LTD. WRITTEN PERMISSION.