



Hydraulic Valve Actuator Reinstallation

MSI Technical Bulletin 067

Subject: Procedures for reinstalling hydraulic actuators and adjusting for proper valve operation.

The intent of this bulletin is to familiarize the user with the recommended procedure to ensure proper alignment when reinstalling hydraulic actuation on MSI plug valves. Proper alignment is crucial for correct valve operation. Improperly aligned actuators lead to valves that do not fully open or close. A partially opened valve will cause premature wear and possible failure of valve internals. A valve that does not shut fully will not provide proper fluid isolation and should be considered a safety risk.

Usage Note: The primary function of MSI plug valves is to direct/isolate the flow of pressurized fluids within a system. Plug valves in general are not to be used to throttle the flow of fluid. In systems where this is required, appropriate throttling valves and/or chokes should be used in conjunction with plug valves.

Instructions for hydraulic actuator installation and alignment on a plug valve:

Note – Always use high quality graphite grease or copper-based anti-seize lubricant during assembly.

- 1) Ensure the valve is fully open, drifted, and greased.
- 2) Determine the required orientation of the hydraulic ports in relation to the valve flow bore. This can be either parallel or perpendicular to valve flow bore. The ports are aligned with the plate dowel pin, so place the mounting plate on the valve with the dowel pin oriented in the desired direction for the hydraulic ports.
- 3) Lubricate socket head cap screws with thread anti-seize, place on lock washers, and install mounting plate onto valve.
- 4) Install actuator adapter onto the valve plug hex.
- 5) Verify that the actuator is in the open position. The groove on the actuator top shaft should be aligned with the hydraulic ports (for parallel orientation). If not connect a hydraulic line to port A (left side port when facing port inlets) and operate actuator until it is open.

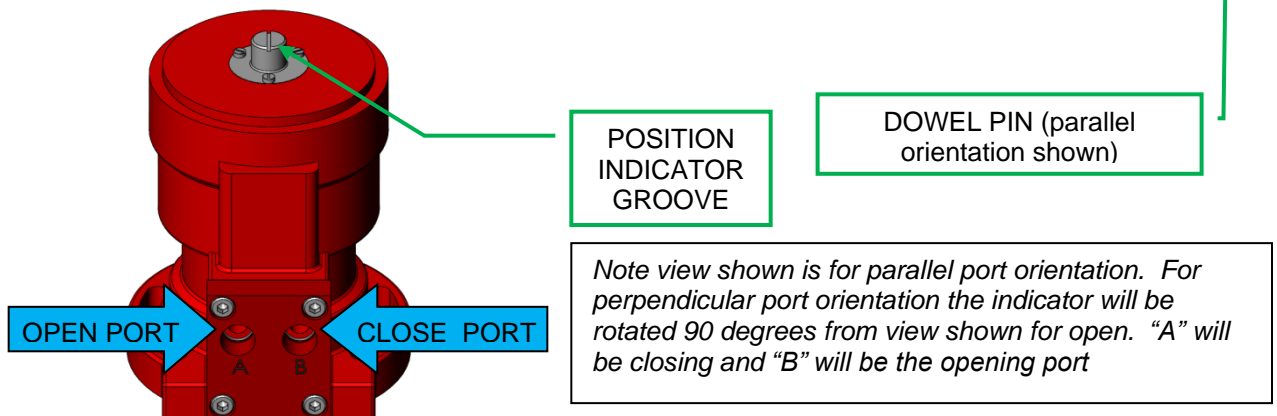
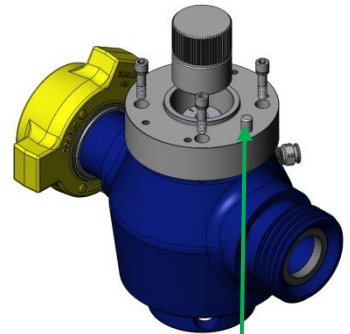

- 6) Lubricate the spline teeth of the actuator.
- 7) Ensure the actuator set screws that lock the actuator position in place on the dowel are loosened. So that they do not interfere when mounting and positioning the actuator.
- 8) Place the actuator onto the mounting plate. Rotate the actuator clockwise/counter-clockwise slightly to allow for the actuator adapter and actuator spline teeth to align and engage.
- 9) Lubricate with anti-seize and loosely install the socket head cap screws and oblong washers. Do not tighten them yet.
- 10) Tighten actuator set screws, alternating sides until both reach the dowel pin simultaneously.
- 11) Operate actuator to shut valve, inspect both valve bores to ensure the valve is completely shut.
- 12) Operate actuator to open valve, inspect valve bore to ensure the valve is fully open and can be drifted. If valve is not fully open loosen and tighten set screws as needed against the dowel pin. This will rotate the actuator and plug until the valve can be drifted.

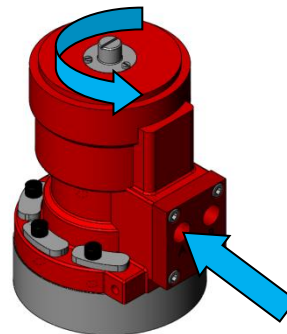
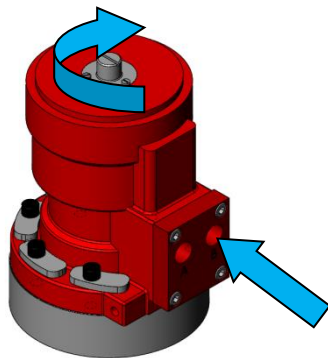
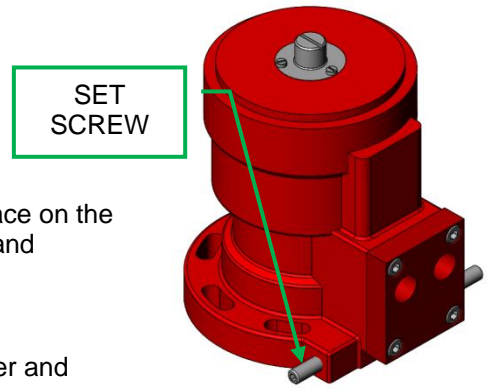

Close operation port and rotating direction

Open operation port and rotating direction

Note – Port A (opening) and Port B (closing) are applicable when the actuator is aligned with the hydraulic ports parallel with the flow bore direction. If the actuator is aligned with the hydraulic ports perpendicular to the flow bore direction then Port A becomes the closing port and Port B becomes the opening port.

- 13) Tighten the actuator mounting screws.

You may contact an MSI representative at sales@diwmsi.com or engineering@diwmsi.com if you have any further questions or concerns.

MSI is a division of Dixie Iron Works, Ltd
 300 W. Main St.
 Alice, Texas 78332, USA
 Phone: 800-242-0059
 Fax: 361-664-4840
www.diwmsi.com