

DETAIL B

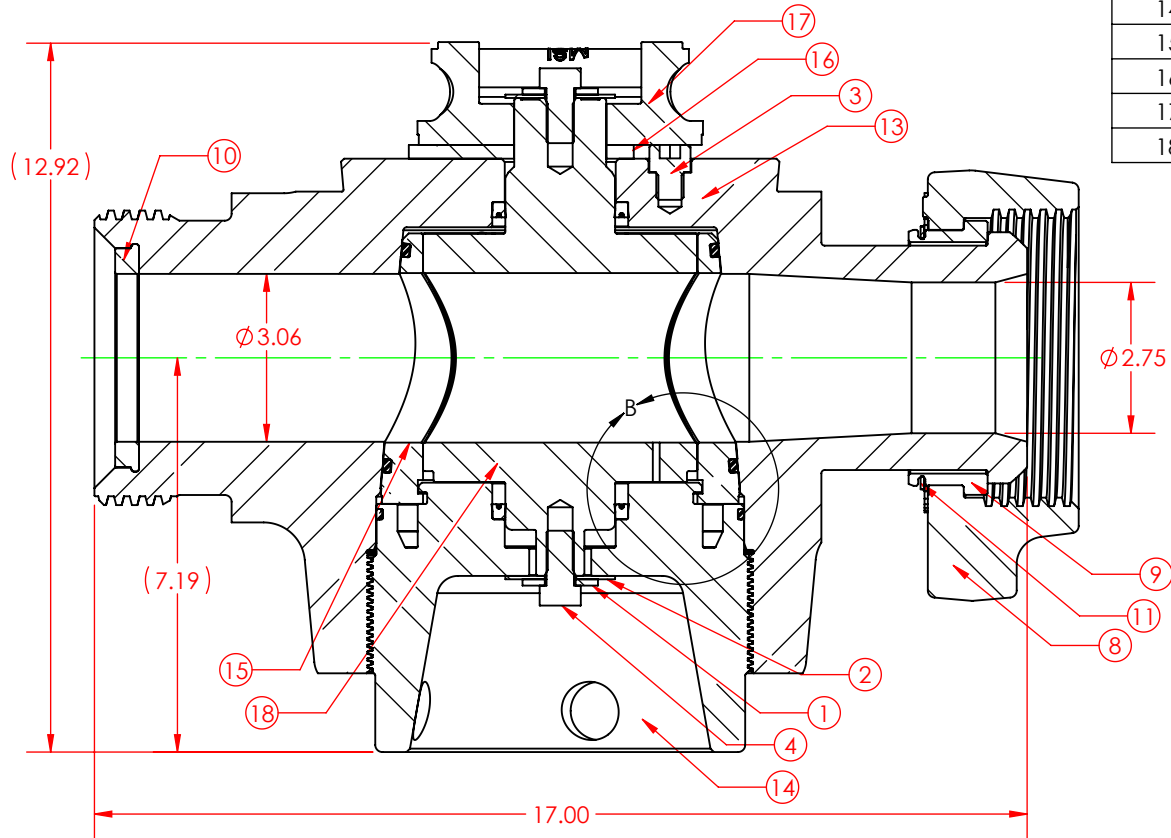

SECTION A-A

ITEM NO.	QTY.	PART NUMBER	DESCRIPTION
1	2	HC0006	FLAT WASHER, 1/2" STD
2	2	HC0007	FLAT WASHER, 1/2" FENDER (2"OD)
3	1	HC0008	SOC HD, 1/2"-13 x 0.50"
4	2	HC0009	HEX HD, 1/2"-20 x 1.00"
5	1	HC0226	GREASE FITTING, 3/4" SAFETAP H2S GBH
6	2	OC0002	O-RING, 3" INSERT H2S (HNBR)
7	1	OC0004	O-RING, 3" ADJ NUT H2S (HNBR)
8	1	UC0005	WINGNUT, 3"1502 H2S
9	1	UC0006	NUT RETAINER SET, 3"1502
10	1	UC0014	RESILIENT SEAL, 3"1502 H2S (HNBR)
11	1	UC0015	SPIRAL RETAINER RING, 3"1502
12	2	VC0005	PLUG SEAL, 1.75" - 3" H2S (HNBR/BRASS)
13	1	VC0023	VLV BODY, 3" x 3"1502 H2S 10M
14	1	VC0029	ADJUSTING NUT, 3" H2S 15M
15	1	VC0041S	INSERT SET, 3" H2S (SPLIT)
16	1	VC0061	STOP COLLAR, 1.75" - 3.00" VALVE
17	1	VC0062	HANDLE ADAPTER, 1.75" - 3.00" VALVE
18	1	VC0070	PLUG, 3" H2S (HEX)

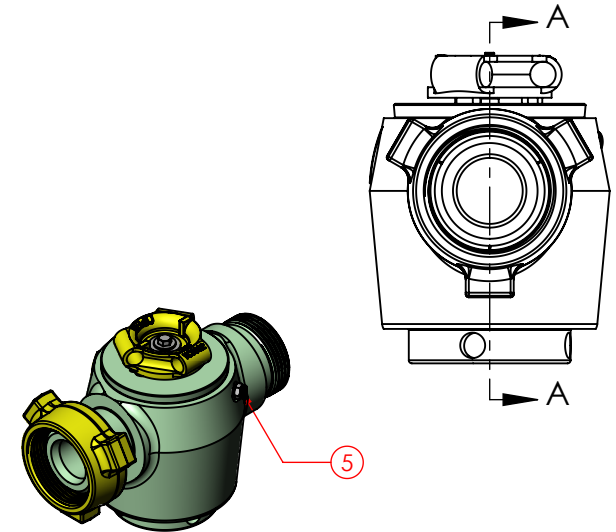

CHANGE MADE

ECN NUMBER	DESCRIPTION		
	VALVE, 3" x 3"1502 H2S 10M (MANUAL)		
WORKING PRESSURE:	TEMPERATURE CLASS:	DRAWN BY:	
10,000 PSI	LU	RSE	
RETAINED FLUIDS:	PR LEVEL:	DATE:	
EE-0.5	1	10/14/11	
WEIGHT	SHEET	PART NUMBER	REV
200 lbs.	SHEET 1 OF 1	VA0016M-S	0

