

2X (7)

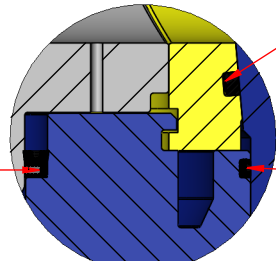

2X (12)

(8) 2X

(9)

DETAIL B

A3

A3

ITEM NO.	QTY.	PART NUMBER	DESCRIPTION
1	4	HC0003	ROLL PIN, 5/16" X 3/4" (LARGE)
2	2	HC0006	FLAT WASHER, 1/2" STD
3	2	HC0007	FLAT WASHER, 1/2" FENDER (2"OD)
4	1	HC0008	SOC HD, 1/2"-13 x 0.50"
5	2	HC0009	HEX HD, 1/2"-20 x 1.00"
6	4	HC0011	ROLL PIN, 3/16" X 11/16" (SMALL)
7	2	HC0226	GREASE FITTING, 3/4" SAFETAP H2S GBH
8	2	OC0001	O-RING, 3" INSERT STD (2-343 BUNA 90)
9	1	OC0003	O-RING, 3" ADJ NUT STD (2-259 BUNA 90)
10	1	VC0029	ADJUSTING NUT, 3" H2S 15M
11	1	VC0056	PLUG, 3" STD (HEX)
12	2	VC0060	PLUG SEAL, 1.75" - 3" STD (BUNA/BRASS)
13	1	VC0061	STOP COLLAR, 1.75" - 3.00" VALVE
14	1	VC0062	HANDLE ADAPTER, 1.75" - 3.00" VALVE
15	1	VC0068S	INSERT SET, 3" STD (SPLIT)
16	1	VC0176	VLV BODY, 3" x 3 1/16 15M STD

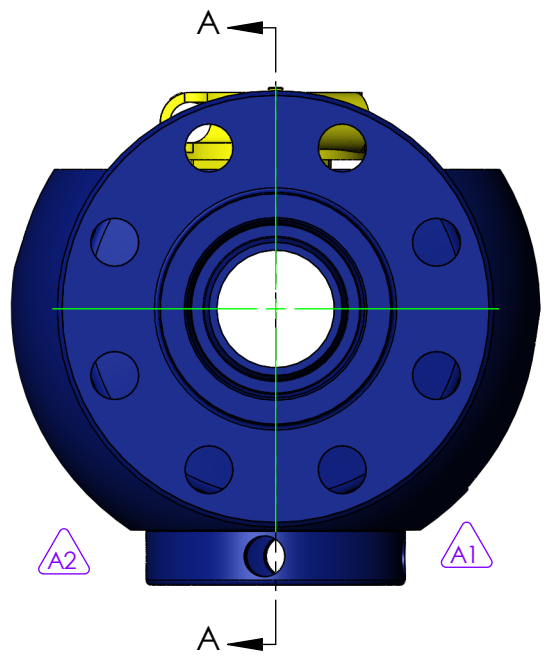

A2

A1

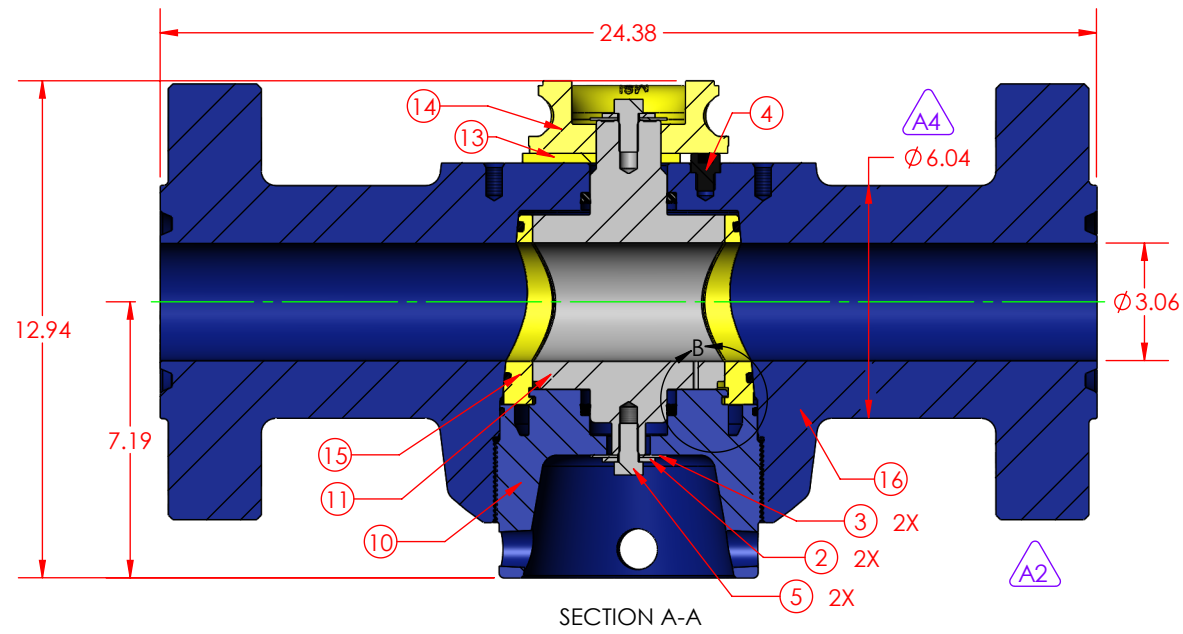

SECTION A-A

A4

A2

ECH NUMBER		DESCRIPTION	
5500		VALVE, 3" x 3 1/16 15M STD (MANUAL)	
WORKING PRESSURE:	TEMPERATURE CLASS:	DRAWN BY:	
15,000 PSI	PU	LMS	
RETAINED FLUIDS:	PR LEVEL:	DATE:	
AA	1	12/17/2014	
WEIGHT:	SHEET:	PART NUMBER:	REV:
425 LBS.	SHEET 1 OF 1	VA0052M-S	A

CHANGE MADE	REVISED BY	LMS	DATE	7/30/2015
1) UPDATED VALVE BODY DUE TO MANUFACTURING PROCESS				
2) REMOVED BOX DIMS				
3) ADDED HC0003 AND HC0011 TO BOM				
4) DIM WAS 5-3/8"; NOW IS 6.04				
5)				
6)				
7)				

300 WEST MAIN ST.
ALICE, TX 78332
www.diwmsi.com
800.242.0059
MSI IS A DIVISION OF DIXIE IRON WORKS, LTD.

THIS DRAWING IS THE PROPERTY OF DIXIE IRON WORKS, LTD. THE BORROWER AGREES BY RECEIVING THE DRAWING TO RETURN IT UPON REQUEST AND TO NEITHER REPRODUCE COPY OR FURNISH INFORMATION FROM IT TO OTHERS WITHOUT EXPRESSED WRITTEN PERMISSION OF DIXIE IRON WORKS, LTD. ALL ARTICLES MANUFACTURED IN ACCORDANCE WITH THIS DRAWING SHALL BE CONSIDERED DESIGNS OF DIXIE IRON WORKS, LTD. AND MAY NOT BE USED OR SOLD WITHOUT DIXIE IRON WORKS, LTD. WRITTEN PERMISSION.