

*NOTE: REFER TO AAG-3LT-4000 DRAWING FOR GEAR-OP BOM

A2

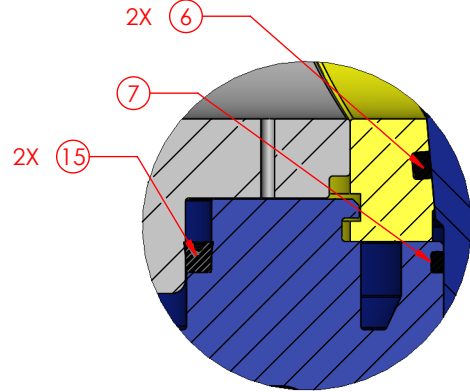

DETAIL B

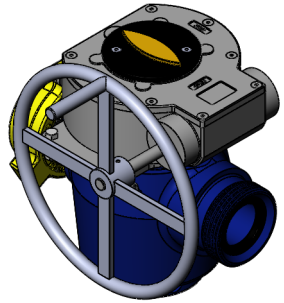
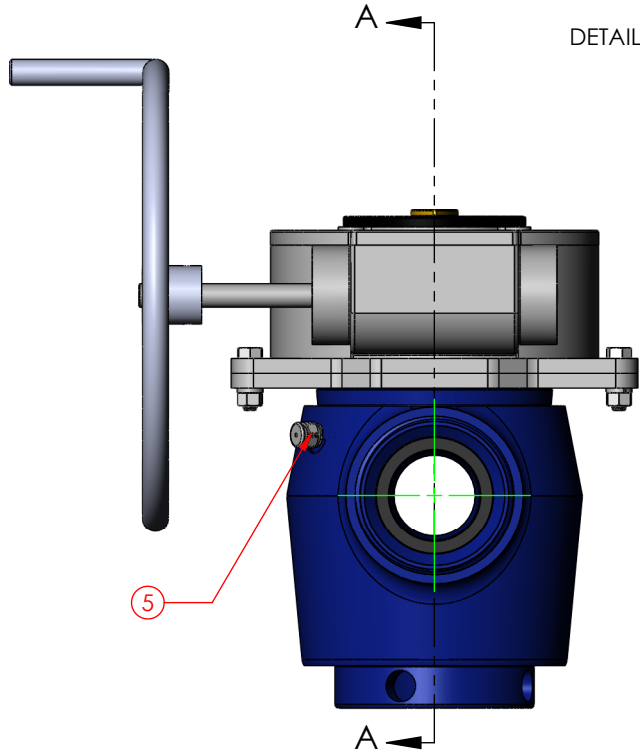

A1

ITEM NO.	QTY.	PART NUMBER	DESCRIPTION
* 1	1	AAG-3LT-4000	PRO GEAR Q4000 S GEAR OPERATOR
2	1	HC0006	FLAT WASHER, 1/2" STD
3	1	HC0007	FLAT WASHER, 1/2" FENDER (2"OD)
4	1	HC0009	HEX HD, 1/2"-20 x 1.00"
5	1	HC0226	GREASE FITTING, 3/4" SAFETAP H2S GBH
6	2	OC0001	O-RING, 3" INSERT STD (2-343 BUNA 90)
7	1	OC0003	O-RING, 3" ADJ NUT STD (2-259 BUNA 90)
8	1	UC0006	NUT RETAINER SET, 3"1502
9	1	UC0009	WINGNUT, 3"1502 STD
10	1	UC0013	RESILIENT SEAL, 3"1502 STD (BUNA)
11	1	UC0015	SPIRAL RETAINER RING, 3"1502
12	1	VC0029	ADJUSTING NUT, 3" H2S 15M
13	1	VC0056	PLUG, 3" STD (HEX)
14	1	VC0058	VLV BODY, 3" x 3"1502 STD 15M
15	2	VC0060	PLUG SEAL, 1.75" - 3" STD (BUNA/BRASS)
16	1	VC0068S	INSERT SET, 3" STD (SPLIT)

A3

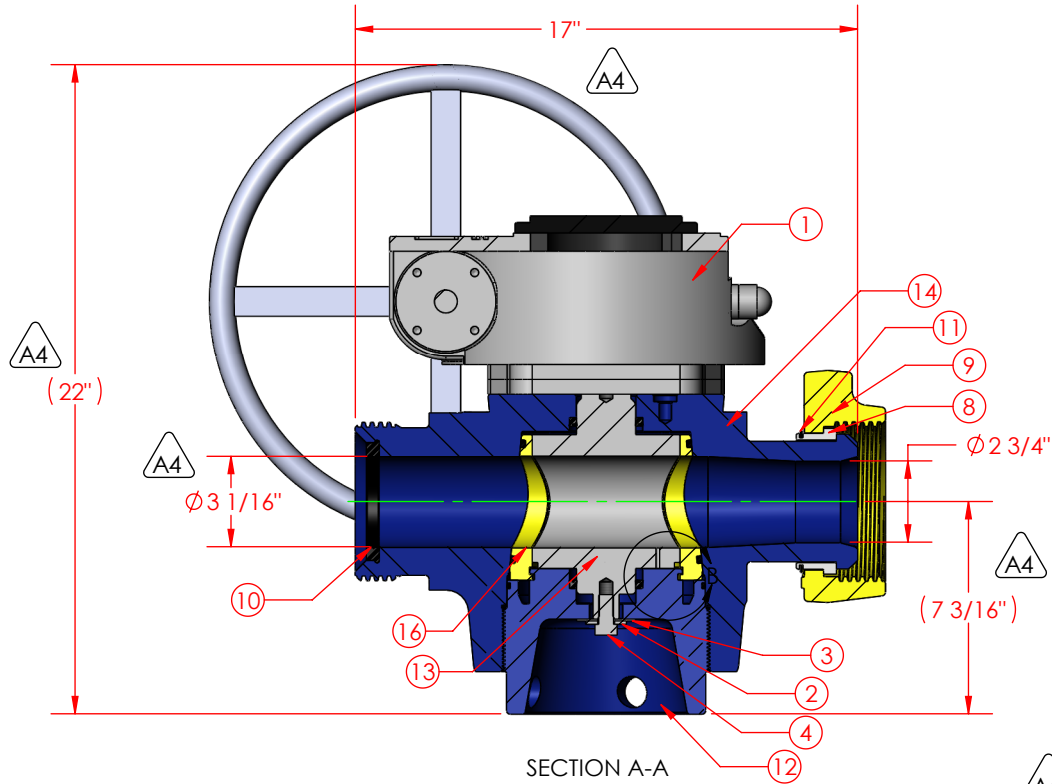

SECTION A-A

A6

ECH NUMBER		DESCRIPTION	
4983		VALVE, 3" x 3"1502 STD 15M (GEAR OP HWTS)	
CHANGE MADE		REVISED BY	DATE
		RSE	01/17/2014
WORKING PRESSURE:	TEMPERATURE CLASS:	DRAWN BY	
15,000 PSI	PU	RSE	
RETAINED FLUIDS:	PR LEVEL:	DATE	
AA	1	08/06/2010	
WEIGHT	SHEET	PART NUMBER	REV.
355 lbs.	SHEET 1 OF 1	VA0055-S	A

- 1) REPLACED AA0007 WITH AAG-3LT-4000
- 2) ADDED NOTE
- 3) WAS VC0058-OA0152; NOW VC0058
- 4) DIMS WERE DECIMAL; NOW FRACTIONAL
- 5) WEIGHT WAS 303; NOW 355 LBS.
- 6) UPDATED DRAWING TEMPLATE
- 7)
- 8)

A5

