

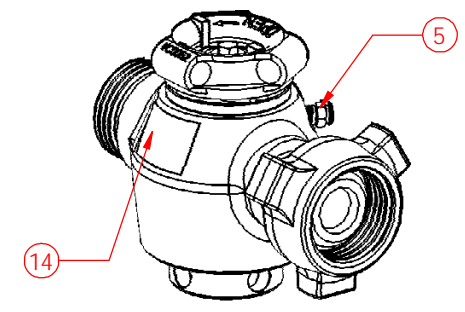

ITEM NO.	QTY.	PART NUMBER	DESCRIPTION
1	2	HC0006	FLAT WASHER, 1/2" STD
2	2	HC0007	FLAT WASHER, 1/2" FENDER (2"OD)
3	1	HC0008	SOC HD, 1/2"-13 x 0.50"
4	2	HC0009	HEX HD, 1/2"-20 x 1.00"
5	1	HC0226	GREASE FITTING, 3/4" SAFETAP H2S GBH
6	2	OC0016	O-RING, 2" INSERT H2S (2-230 EOL985-85)
7	1	OC0020	O-RING, 2" ADJ NUT H2S (2-245 EOL985)
8	1	UC0003	NUT RETAINER SET, 2"1502
9	1	UC0004	SPIRAL RETAINER RING, 2"1502
10	1	UC0012	RESILIENT SEAL, 2"1502 H2S (HSN)
11	1	UC0131	WINGNUT, 2"1502 H2S (10LBS)
12	2	VC0005	PLUG SEAL, 2" H2S (HSN/BRASS)
13	1	VC0011	VLV BODY, 2" x 2"1502FM
14	1	VC0013	NAME TAG-VALVE (MSI/DIXIE)
15	1	VC0028	ADJUSTING NUT, 2" H2S
16	1	VC0049S	INSERT SET, 2" H2S (SPLIT)
17	1	VC0050	PLUG, 2"H2S
18	1	VC0061	STOP COLLAR, 2", 3", 4"
19	1	VC0062	HANDLE ADAPTER, 2", 3", 4"

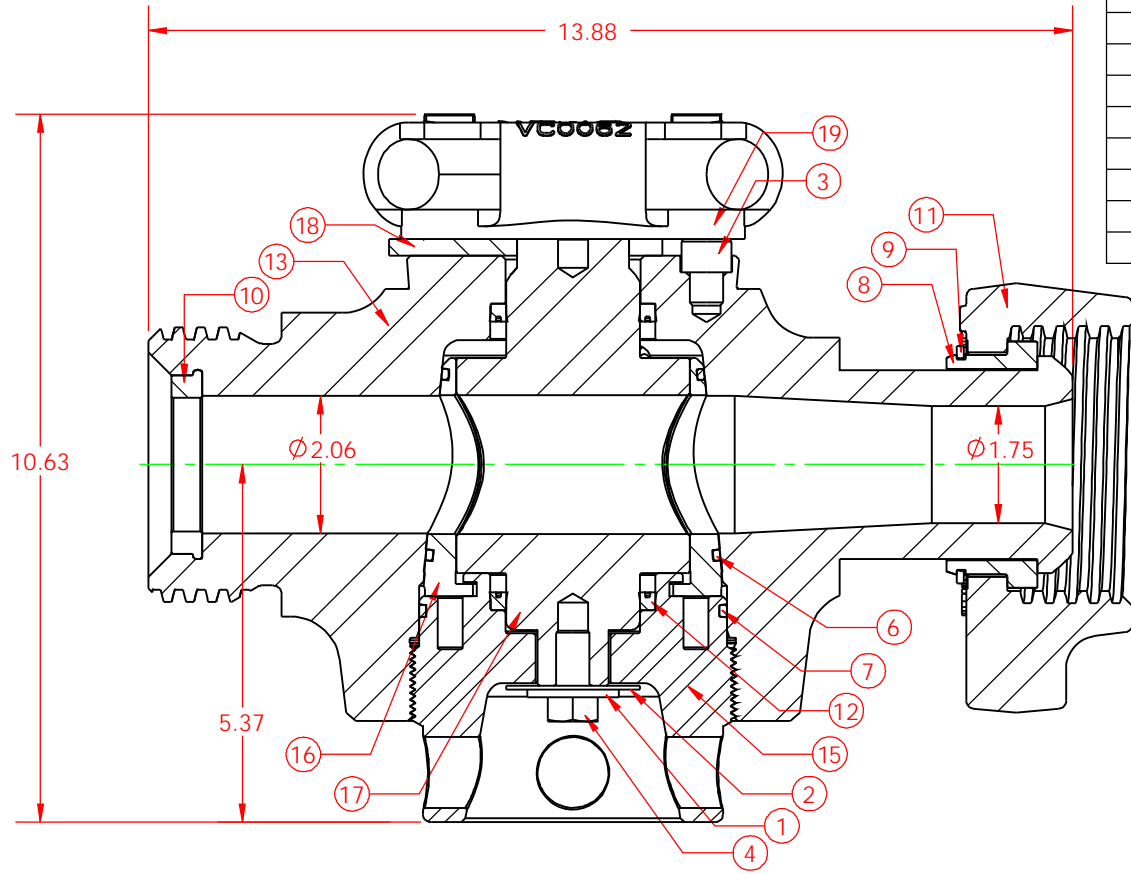

DESCRIPTION VALVE, 2" x 2"1502 H2S 10M		 300 West Main Street Alice, TX 78332 www.diwmsi.com 800.242.0059 <small>MSI is a division of Dixon Iron Works, Ltd.</small>
MATERIAL/ HEAT TREAT/ WELD PROCEDURE SOUR SERVICE 10,000 PSI WORKING PRESSURE	DRAWN BY RMR DATE 1/16/2009	
WEIGHT 97 LBS	SHEET SHEET 1 OF 1	PART NUMBER VA0109-S REV 0