

A

B

C

D

E

F

G

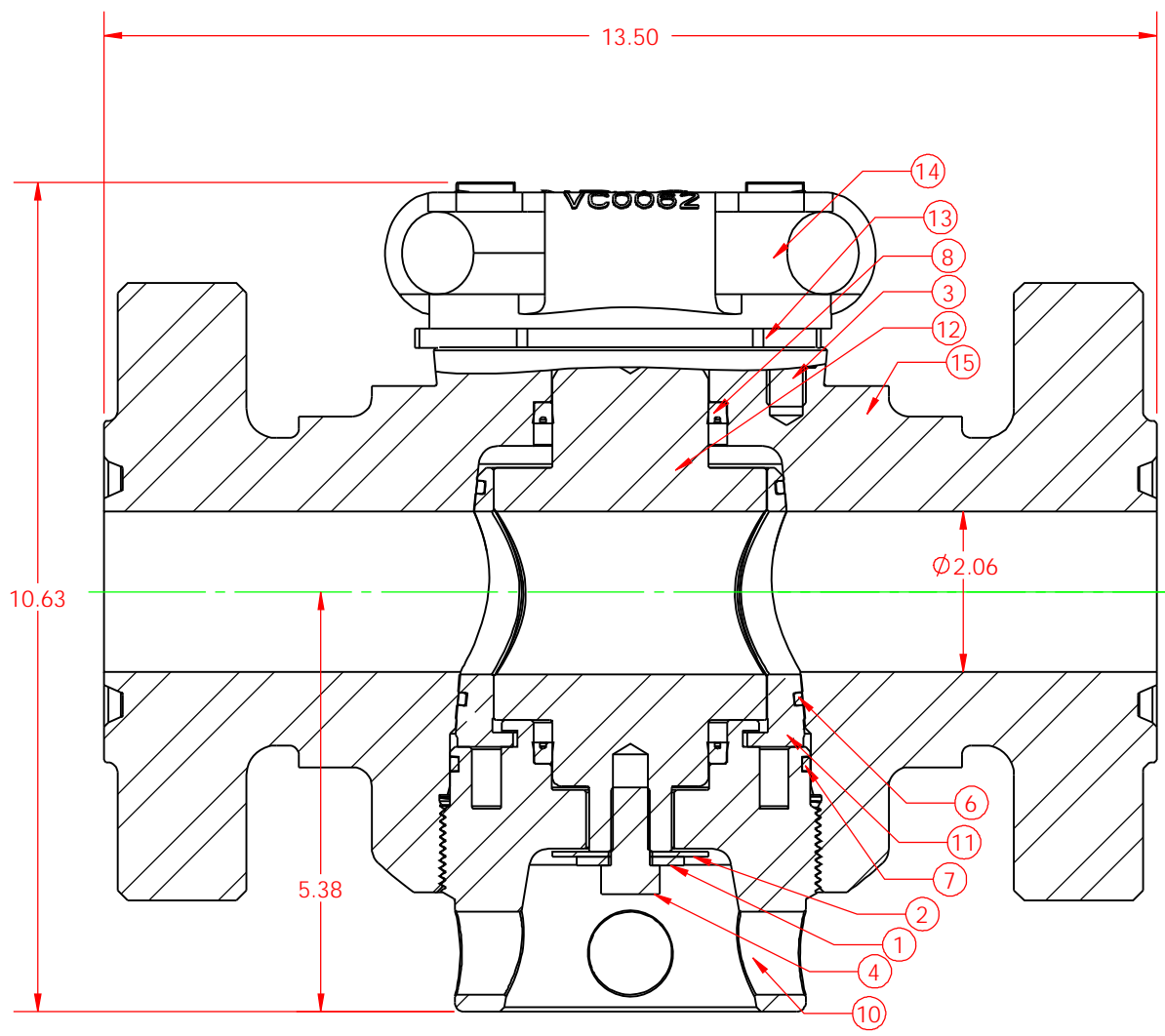

ITEM NO.	QTY.	PART NUMBER	DESCRIPTION
1	2	HC0006	FLAT WASHER, 1/2" STD
2	2	HC0007	FLAT WASHER, 1/2" FENDER (2"OD)
3	1	HC0008	SOC HD, 1/2"-13 x 0.50"
4	2	HC0009	HEX HD, 1/2"-20 x 1.00"
5	1	HC0226	GREASE FITTING, 3/4" SAFETAP H2S GBH
6	2	OC0016	O-RING, 2" INSERT H2S
7	1	OC0020	O-RING, 2" ADJ NUT H2S
8	2	VC0005	PLUG SEAL, 2" H2S (HNBR/BRASS)
9	1	VC0013	NAME TAG - VALVE (MSI/DIXIE) 2X3
10	1	VC0028	ADJUSTING NUT, 2" H2S
11	1	VC0049S	INSERT SET, 2" H2S (SPLIT)
12	1	VC0050	PLUG, 2"H2S
13	1	VC0061	STOP COLLAR, 2",3",4"
14	1	VC0062	HANDLE ADAPTER, 2", 3", 4"
15	1	VC0076	VLV BODY, 2" x 2 1/16 10M H2S

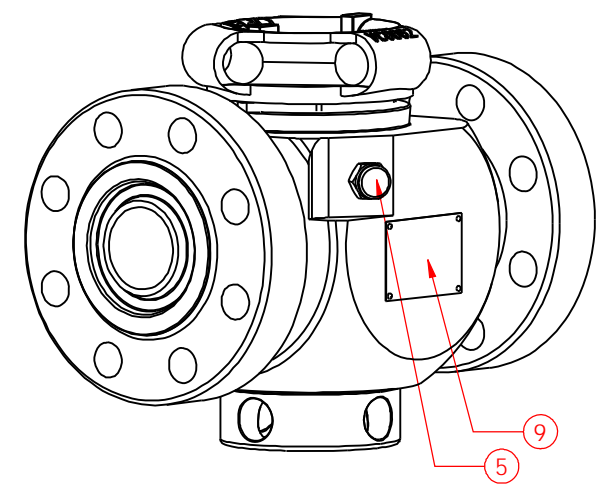

<p>THIS DRAWING IS THE PROPERTY OF DIXIE IRON WORKS, LTD. THE BORROWER AGREES BY RECEIVING THE DRAWING TO RETURN IT UPON REQUEST AND TO NEITHER REPRODUCE COPY OR FURNISH INFORMATION FROM IT TO OTHERS WITHOUT EXPRESSED WRITTEN PERMISSION OF DIXIE IRON WORKS, LTD. ALL ARTICLES MANUFACTURED IN ACCORDANCE WITH THIS DRAWING SHALL BE CONSIDERED DESIGNS OF DIXIE IRON WORKS, LTD. AND MAY NOT BE USED OR SOLD WITHOUT DIXIE IRON WORKS, LTD. WRITTEN PERMISSION.</p>	CHANGE MADE	ECN NUMBER	DESCRIPTION	<p>300 West Main Street Alice, TX 78332 www.divmsi.com 800.242.0059 MSI is a division of Dixie Iron Works, Ltd.</p>	
			VALVE, 2" x 2 1/16 10M H2S		
			MATERIAL/HEAT TREAT/WELD PROCEDURE SOUR SERVICE 10,000 PSI WORKING PRESSURE		DRAWN BY RSE
			THIRD ANGLE PROJECTION		DATE 03/01/10
		WEIGHT 134 lbs.	SHEET SHEET 1 OF 1	PART NUMBER VA0134-S	
				REV 0	