

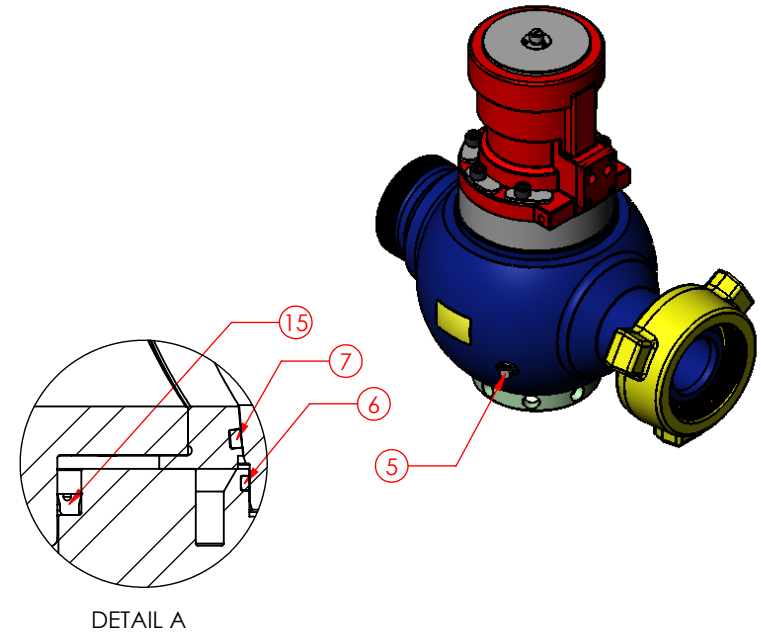

NOTE: REFER TO AA0064-4LT DRAWING FOR ACTUATOR PARTS.

ITEM NO.	QTY.	PART NUMBER	DESCRIPTION
1	1	AA0064-4LT	ACT ASSY, DAMCOS BRC4000 4"LT VALVE
2	1	HC0006	FLAT WASHER, 1/2" STD
3	1	HC0007	FLAT WASHER, 1/2" FENDER (2"OD)
4	1	HC0009	HEX HD, 1/2"-20 x 1.00"
5	2	HC0226	GREASE FITTING, 3/4" SAFETAP H2S GBH
6	1	OC0047	O-RING, 4" ADJ NUT STD (BUNA)
7	2	OC0048	O-RING, 4" INSERT STD (BUNA)
8	1	UC0289	WINGNUT, 4"1502 STD
9	1	UC0290	NUT RETAINER SET, 4"1502
10	1	UC0291	SPIRAL RETAINING RING, 4"1502
11	1	UC0241	RESILIENT SEAL, 4"602/1002/1502 STD (BUNA)
12	1	VC0310	PLUG, 4" STD
13	1	VC0311S	INSERT SET, 4" STD (SPLIT)
14	1	VC0312	ADJUSTING NUT, 4" H2S
15	2	VC0313	PLUG SEAL, 4" STD (BUNA/BRASS)
16	1	VC0319	VLV BODY, 4" x 4"1502 STD 15M (4330)

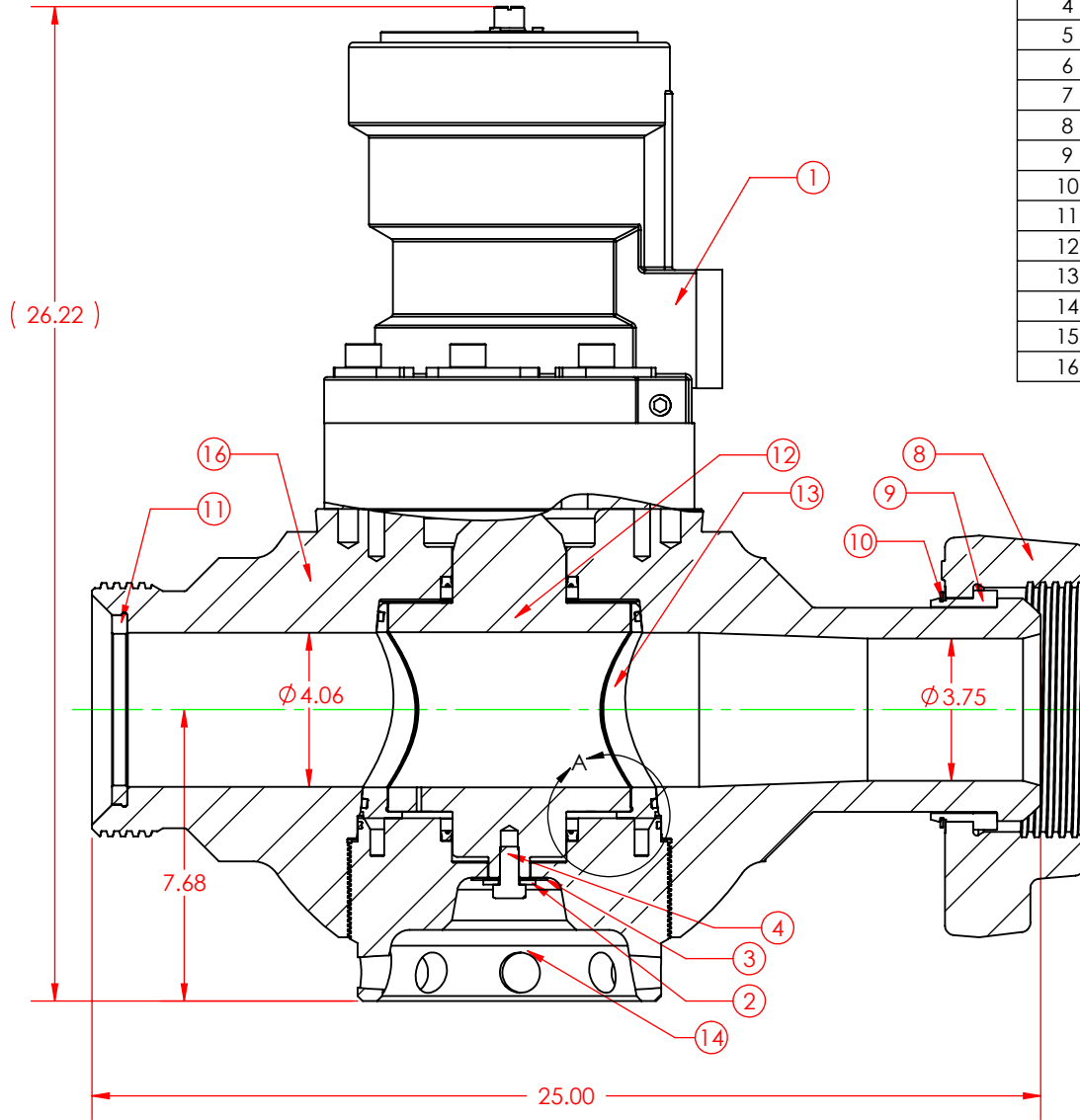

<p>THIS DRAWING IS THE PROPERTY OF DIXIE IRON WORKS, LTD. THE BORROWER AGREES BY RECEIVING THE DRAWING TO RETURN IT UPON REQUEST AND TO NEITHER REPRODUCE COPY OR FURNISH INFORMATION FROM IT TO OTHERS WITHOUT EXPRESSED WRITTEN PERMISSION OF DIXIE IRON WORKS, LTD. ALL ARTICLES MANUFACTURED IN ACCORDANCE WITH THIS DRAWING SHALL BE CONSIDERED DESIGNS OF DIXIE IRON WORKS, LTD. AND MAY NOT BE USED OR SOLD WITHOUT DIXIE IRON WORKS, LTD. WRITTEN PERMISSION.</p>	CHANGE MADE	ECN NUMBER	DESCRIPTION	 <p>300 West Main Street Alice, TX 78332 www.diwmsi.com 800.242.0059 MSI is a division of Dixie Iron Works, Ltd.</p>	
			VALVE, 4" x 4"1502 STD 15M (ACTUATED)		
			MATERIAL/ HEAT TREAT/ WELD PROCEDURE STANDARD SERVICE 15,000 PSI WORKING SERVICE		DRAWN BY HAHII
			THIRD ANGLE PROJECTION		DATE 4/15/05
		WEIGHT 635 LBS	SHEET SHEET 1 OF 1	PART NUMBER VA0366	
				REV 0	