

ITEM NO.	QTY.	PART NUMBER	DESCRIPTION
*1	1	AAH-2LT-2000	ACT ASSY, DAMCOS BRC2000 2"LT VALVE & 1.75"
2	1	HC0006	FLAT WASHER, 1/2" STD
3	1	HC0007	FLAT WASHER, 1/2" FENDER (2"OD)
4	1	HC0009	HEX HD, 1/2"-20 x 1.00"
5	1	HC0226	GREASE FITTING, 3/4" SAFETAP H2S GBH
6	2	OC0011	O-RING, 2" INSERT STD (2-230 BUNA 90)
7	1	OC0012	O-RING, 2" ADJ NUT STD (2-245 BUNA 90)
8	1	UC0002	WINGNUT, 2"1502 STD
9	1	UC0003	NUT RETAINER SET, 2"1502
10	1	UC0004	SPIRAL RETAINER RING, 2"1502
11	1	UC0011	RESILIENT SEAL, 2"1502 STD (BUNA)
12	1	VC0022	VLV BODY, 2" x 2"1502 STD 15M
13	1	VC0024	PLUG, 2" STD
14	1	VC0027S	INSERT SET, 2" STD (SPLIT)
15	1	VC0028	ADJUSTING NUT, 2" H2S
16	2	VC0060	PLUG SEAL, 1.75" - 3" STD (BUNA/BRASS)

*NOTE: REFER TO AAH-2LT-2000 DRAWING FOR ACTUATOR BOM

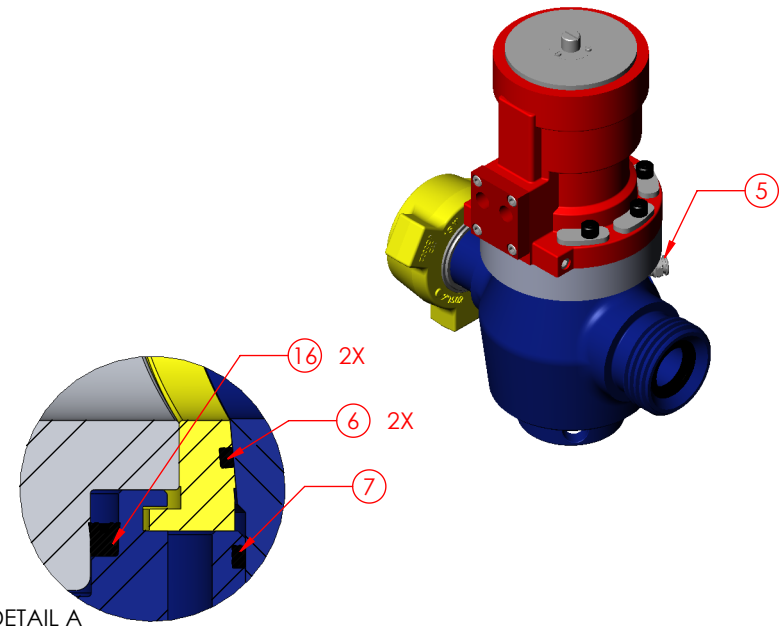

DETAIL A

ECN NUMBER	DESCRIPTION		
4949	VALVE, 2" x 2"1502 STD 15M (HYD ACTD)		
WORKING PRESSURE:	TEMPERATURE CLASS:	DRAWN BY:	
15,000 PSI	PU	RSE	
RETAINED FLUIDS:	PR LEVEL:	DATE:	
AA	1	01/28/10	
WEIGHT:	SHEET:	PART NUMBER:	
165 LBS.	SHEET 1 OF 1	VA0458-S	

MSI
 300 WEST MAIN ST.
 ALICE, TX 78332
 www.diwmsi.com
 800.242.0059
MSI IS A DIVISION OF DIXIE IRON WORKS, LTD.

CHANGE MADE	REVISED BY	RSE	DATE	10/31/2013
1)	WEIGHT WAS 216 LBS.; NWO 165 LBS.			
2)				
3)				
4)				
5)				
6)				
7)				
8)				



THIS DRAWING IS THE PROPERTY OF DIXIE IRON WORKS, LTD. THE BORROWER AGREES BY RECEIVING THE DRAWING TO RETURN IT UPON REQUEST AND TO NEITHER REPRODUCE COPY OR FURNISH INFORMATION FROM IT TO OTHERS WITHOUT EXPRESSED WRITTEN PERMISSION OF DIXIE IRON WORKS, LTD. ALL ARTICLES MANUFACTURED IN ACCORDANCE WITH THIS DRAWING SHALL BE CONSIDERED DESIGNS OF DIXIE IRON WORKS, LTD. AND MAY NOT BE USED OR SOLD WITHOUT DIXIE IRON WORKS, LTD. WRITTEN PERMISSION.