

NOTE:
REFER TO AAG-4LT-6500 DRAWING FOR ACTUATOR BOM.

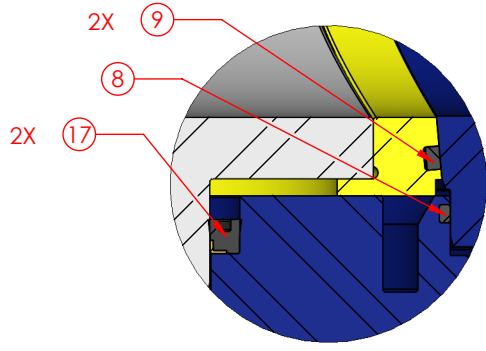

DETAIL B

ITEM NO.	QTY.	PART NUMBER	DESCRIPTION
1	1	AAG-4LT-6500	GEAR OP ASSY, PRO GEAR Q6500 4"LT VALVE
2	4	HC0003	ROLL PIN, 5/16" X 3/4" (LARGE)
3	1	HC0006	FLAT WASHER, 1/2" STD
4	1	HC0007	FLAT WASHER, 1/2" FENDER (2"OD)
5	1	HC0009	HEX HD, 1/2"-20 x 1.00"
6	4	HC0011	ROLL PIN, 3/16" X 11/16" (SMALL)
7	2	HC0226	GREASE FITTING, 3/4" SAFETAP H2S GBH
8	1	OC0047	O-RING, 4" ADJ NUT STD (2-264 BUNA 90)
9	2	OC0048	O-RING, 4" INSERT STD (2-351 BUNA 90)
10	1	UC0139	NUT RETAINER SET, 4"602/1002
11	1	UC0140	SPIRAL RETAINER RING, 4" 1002
12	1	UC0241	RESILIENT SEAL, 4"602/1002/1502 STD (BUNA)
13	1	UC0270	WINGNUT, 4"1002 STD DETACHABLE
14	1	VC0310	PLUG, 4" STD
15	1	VC0311S	INSERT SET, 4" STD (SPLIT)
16	1	VC0312	ADJUSTING NUT, 4" H2S
17	2	VC0313	PLUG SEAL, 4" - 5" STD (BUNA/BRASS)
18	1	VC0428	VLV BODY, 4" x 4"1002 STD 10M

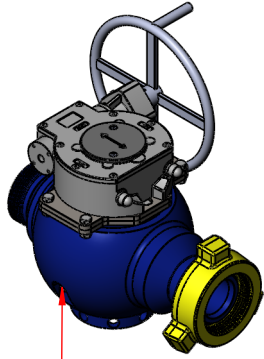
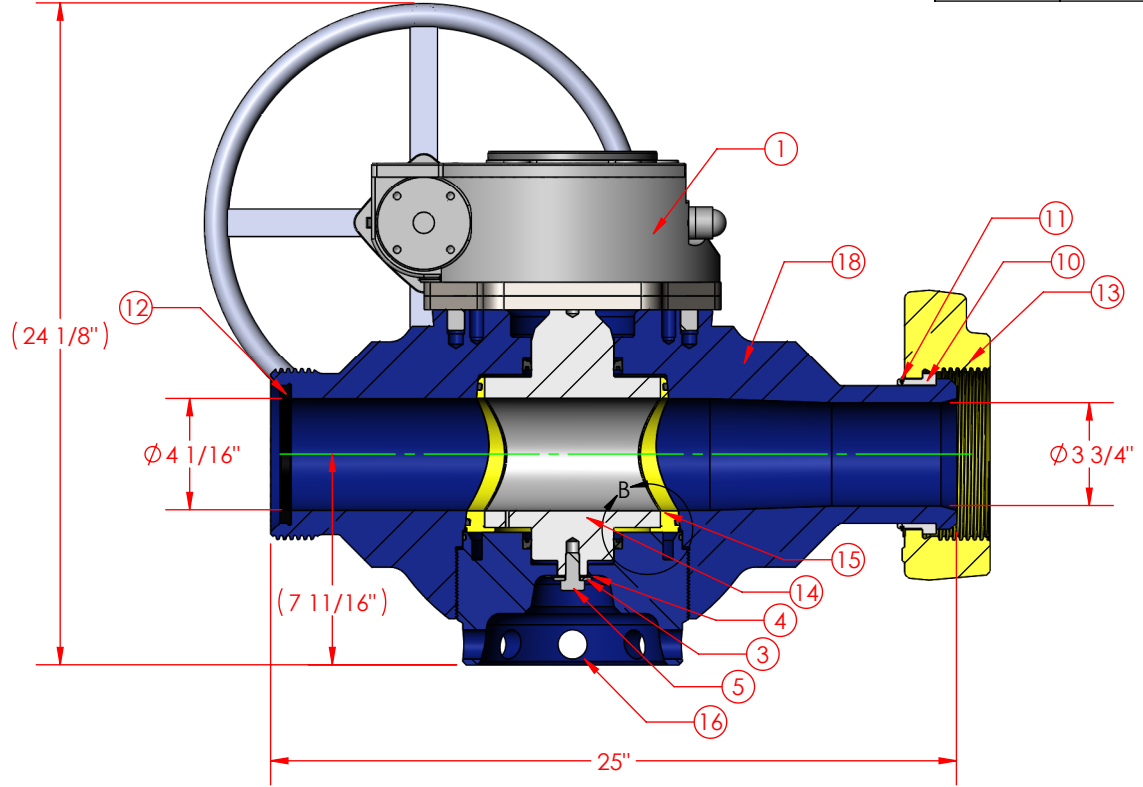

SECTION A-A

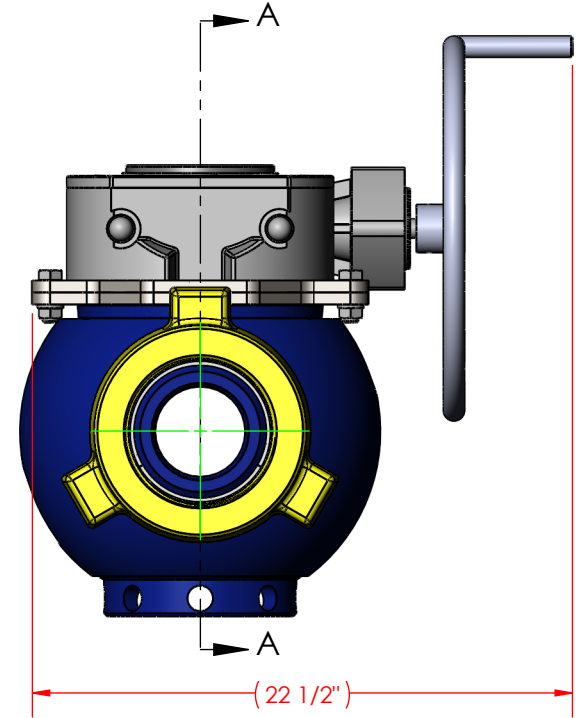

CHANGE MADE	REVISED BY	DATE
1)		
2)		
3)		
4)		
5)		
6)		
7)		
8)		

ECH NUMBER		DESCRIPTION	
		VALVE, 4" x 4"1002 STD 10M (GEAR OP HWTS)	
WORKING PRESSURE:	TEMPERATURE CLASS:	DRAWN BY:	
10,000	PU	RSE	
RETAINED FLUIDS:	PR LEVEL:	DATE:	
AA	1	11/11/2015	
WEIGHT:	SHEET:	PART NUMBER:	REV:
622 lbs.	SHEET 1 OF 1	VA0466-S	0

300 WEST MAIN ST.
ALICE, TX 78332
www.diwmsi.com
800.242.0059
MSI IS A DIVISION OF DIXIE IRON WORKS, LTD.

THIS DRAWING IS THE PROPERTY OF DIXIE IRON WORKS, LTD. THE BORROWER AGREES BY RECEIVING THE DRAWING TO RETURN IT UPON REQUEST AND TO NEITHER REPRODUCE COPY OR FURNISH INFORMATION FROM IT TO OTHERS WITHOUT EXPRESSED WRITTEN PERMISSION OF DIXIE IRON WORKS, LTD. ALL ARTICLES MANUFACTURED IN ACCORDANCE WITH THIS DRAWING SHALL BE CONSIDERED DESIGNS OF DIXIE IRON WORKS, LTD. AND MAY NOT BE USED OR SOLD WITHOUT DIXIE IRON WORKS, LTD. WRITTEN PERMISSION.