

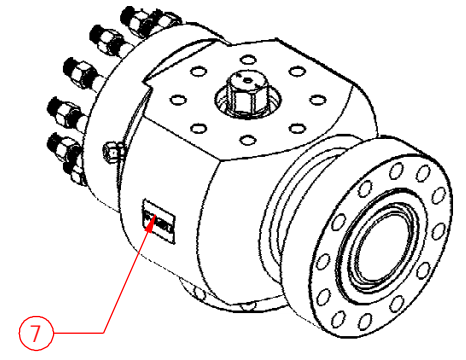

ITEM NO.	QTY.	PART NUMBER	DESCRIPTION
1	1	HC0109	FLAT WASHER, 3/4" STD
2	3	HC0162	GREASE FITTING, 3/4" SAFETAP H2S GBH/1"-14 w/VENT CAP
3	12	HC0186	TAP END STUD w/NUT, 5 1/8 10M (1 1/8"-8 x 6.00")
4	2	OC0083	O-RING, 5" INSERT STD
5	1	OC0084	O-RING, 5" ADJ NUT STD
6	1	OC0121	O-RING, 5" ADJ NUT FACE SEAL RING STD
7	1	VC0013	NAME TAG - VALVE (MSI/DIXIE) 2x3
8	2	VC0313	PLUG SEAL, 4" STD (BUNA/BRASS)
9	1	VC0468	PLUG, 5" STD *GREASE FITTING
10	1	VC0469S	INSERT SET, 5" STD (SPLIT)
11	1	VC0470	ADJUSTING NUT, 5" STD
12	1	VC0480	VLV BODY, 5" X 5 1/8 10M STUD X FLG
13	1	VC0592	ADJUSTING NUT, 5" STD SEAL RING

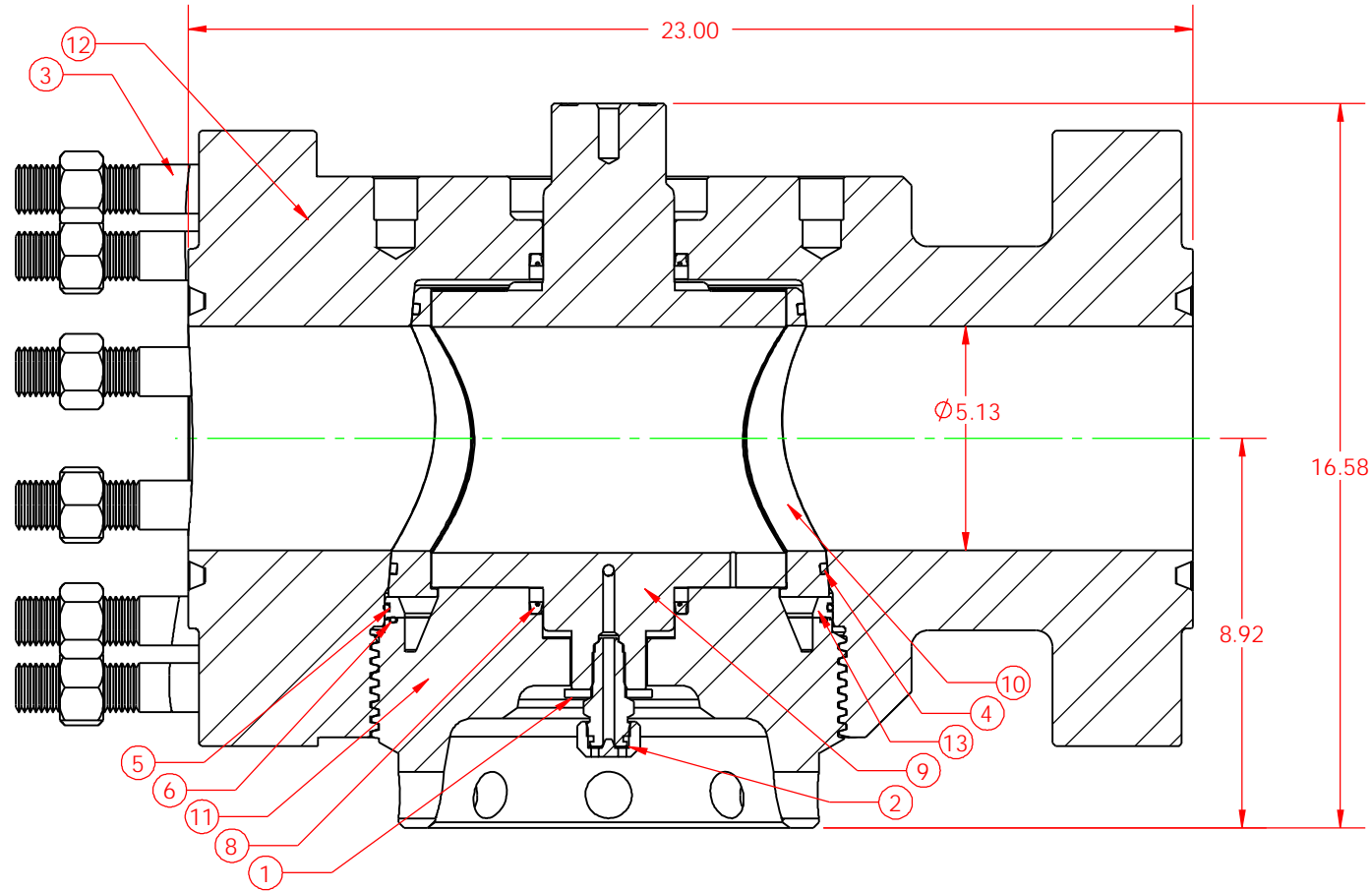

<p>THIS DRAWING IS THE PROPERTY OF DIXIE IRON WORKS, LTD. THE BORROWER AGREES BY RECEIVING THE DRAWING TO RETURN IT UPON REQUEST AND TO NEITHER REPRODUCE COPY OR FURNISH INFORMATION FROM IT TO OTHERS WITHOUT EXPRESSED WRITTEN PERMISSION OF DIXIE IRON WORKS, LTD. ALL ARTICLES MANUFACTURED IN ACCORDANCE WITH THIS DRAWING SHALL BE CONSIDERED DESIGNS OF DIXIE IRON WORKS, LTD. AND MAY NOT BE USED OR SOLD WITHOUT DIXIE IRON WORKS, LTD. WRITTEN PERMISSION.</p>	CHANGE MADE	ECN NUMBER	DESCRIPTION		 300 West Main Street Alice, TX 78332 www.diwmsi.com 800.242.0059 <small>MSI is a division of Dixie Iron Works, Ltd.</small>	
			VALVE, 5" x 5 1/8 10M STUDxFLG STD *ACT PATTERN *SPLIT			
			MATERIAL/HEAT TREAT/WELD PROCEDURE	DRAWN BY		
			STANDARD SERVICE	RSE		
			DATE	01/04/2010		
		THIRD ANGLE PROJECTION	PART NUMBER	VA0567-S	REV	
		WEIGHT 896 LBS	SHEET SHEET 1 OF 1		0	