

ITEM NO.	QTY.	PART NUMBER	DESCRIPTION
1	1	AA0007	GEAR OPERATOR, WMI 12M w/16" HANDWHEEL
2	1	HC0006	FLAT WASHER, 1/2" STD
3	1	HC0007	FLAT WASHER, 1/2" FENDER (2" OD)
4	1	HC0009	HEX HD, 1/2"-20 x 1.00"
5	6	HC0023	LOCK WASHER, 1/2" HIGH COLLAR
6	4	HC0034	SOC HD, 1/2"-13 x 1.50"
7	2	HC0098	HEX NUT, 1/2"-13
8	2	HC0226-PSL3	GREASE FITTING, 3/4" SAFETAP H2S GBH - PSL3
9	2	HC0369	HEX HD, 1/2"-13 x 4.00" FULLY THREADED
10	1	OC0054	O-RING, 4" ADJ NUT H2S (VITON)
11	2	OC0055	O-RING, 4" INSERT H2S (VITON)
12	1	VC0312-PSL3	ADJUSTING NUT, 4" H2S PSL3
13	1	VC0389S-PSL3	INSERT SET, 4" H2S PSL3 (SPLIT)
14	1	VC0390-PSL3	PLUG, 4" H2S PSL3
15	2	VC0563	PLUG SEAL, 4" H2S (VITON/BRASS)
16	1	VC0735-PSL3	VLV BODY, 4" x 4 1/16 15M H2S CRA 625 PSL3

A

B

C

D

E

F

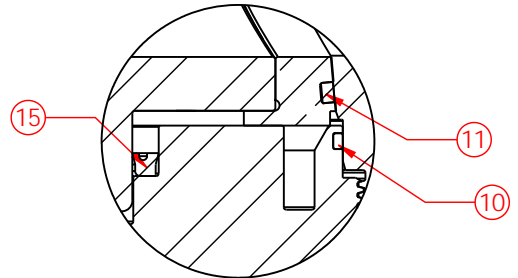
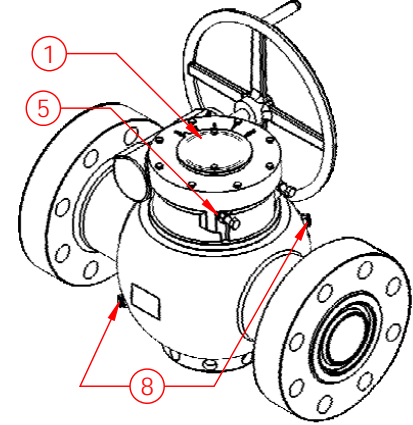
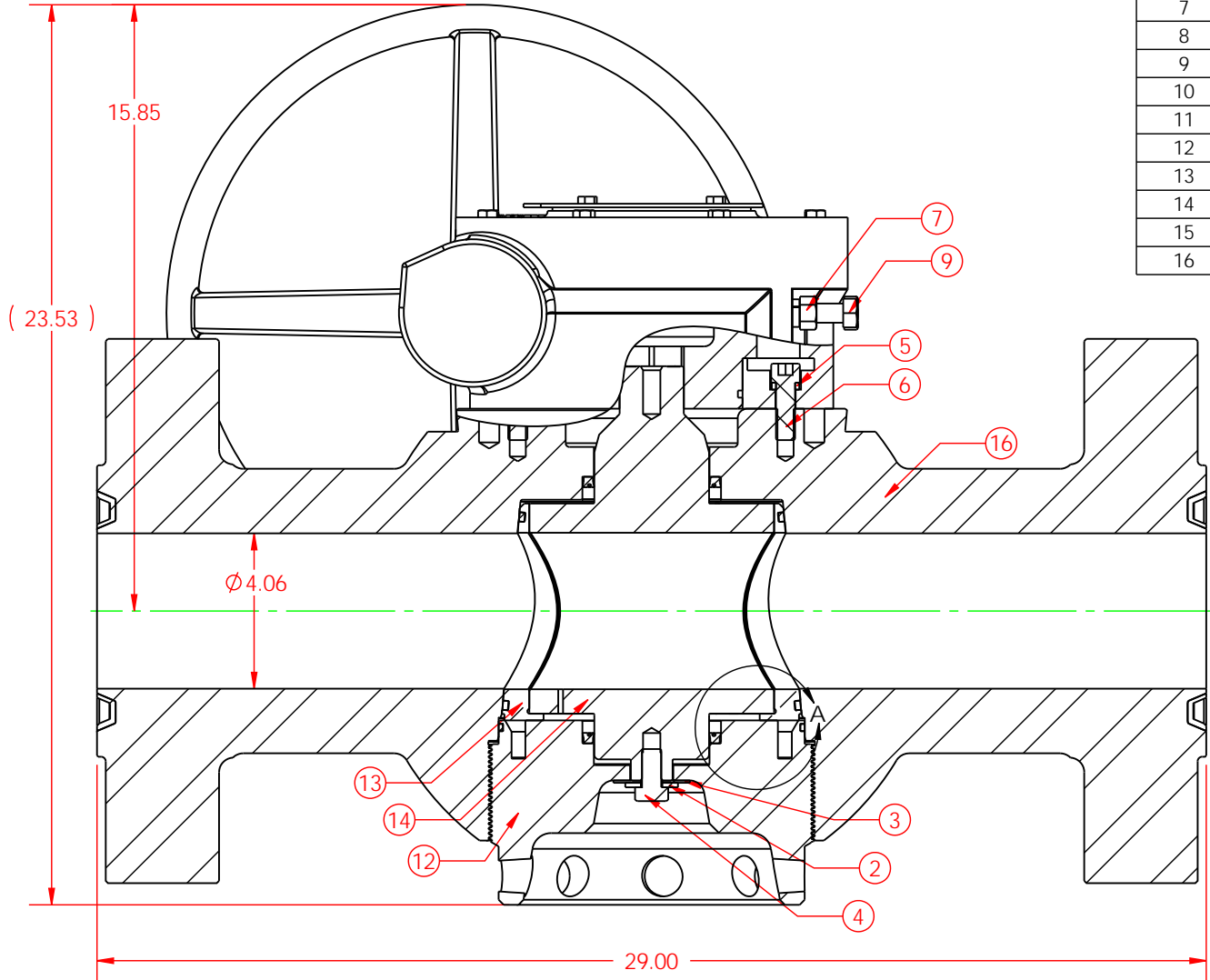

DETAIL A

G

THIS DRAWING IS THE PROPERTY OF DIXIE IRON WORKS, LTD. THE BORROWER AGREES BY RECEIVING THE DRAWING TO RETURN IT UPON REQUEST AND TO NEITHER REPRODUCE COPY OR FURNISH INFORMATION FROM IT TO OTHERS WITHOUT EXPRESSED WRITTEN PERMISSION OF DIXIE IRON WORKS, LTD. ALL ARTICLES MANUFACTURED IN ACCORDANCE WITH THIS DRAWING SHALL BE CONSIDERED DESIGNS OF DIXIE IRON WORKS, LTD. AND MAY NOT BE USED OR SOLD WITHOUT DIXIE IRON WORKS, LTD. WRITTEN PERMISSION.

CHANGE MADE	ECN NUMBER

DESCRIPTION	
VALVE, 4" x 4 1/16 15M H2S 625 RG VITON (GEAR OP) PSL3	
MATERIAL/HEAT TREAT/ WELD PROCEDURE	DRAWN BY
SOUR SERVICE	RSE
15,000 PSI WORKING PRESSURE	DATE
	03/17/10
WEIGHT	SHEET
789 lbs.	SHEET 1 OF 1
PART NUMBER	REV
VA0822-SV-PSL3	0

300 West Main Street
Alice, TX 78332
www.dixieiron.com
800.242.0059
MSI is a division of Dixie Iron Works, Ltd.