

ITEM NO.	QTY.	PART NUMBER	DESCRIPTION
1	8	HC0003	ROLL PIN, 5/16" X 3/4" (LARGE)
2	4	HC0006	FLAT WASHER, 1/2" STD
3	4	HC0007	FLAT WASHER, 1/2" FENDER (2'OD)
4	2	HC0008	SOC HD, 1/2"-13 x 0.50"
5	4	HC0009	HEX HD, 1/2"-20 x 1.00"
6	8	HC0011	ROLL PIN, 3/16" X 11/16" (SMALL)
7	16	HC0067	TAP END STUD w/NUT, 2 1/16 15M (7/8"-9 UNCx4.38")
8	4	HC0226	GREASE FITTING, 3/4" SAFETAP H2S GBH
9	4	OC0001	O-RING, 3" INSERT STD (2-343 BUNA 90)
10	2	OC0003	O-RING, 3" ADJ NUT STD (2-259 BUNA 90)
11	2	VC0029	ADJUSTING NUT, 3" H2S 15M
12	2	VC0056	PLUG, 3" STD (HEX)
13	4	VC0060	PLUG SEAL, 1.75" - 3" STD (BUNA/BRASS)
14	2	VC0061	STOP COLLAR, 1.75" - 3.00" VALVE
15	2	VC0062	HANDLE ADAPTER, 1.75" - 3.00" VALVE
16	2	VC0068S	INSERT SET, 3" STD (SPLIT)
17	1	VC0732	VLV BODY, 3" x 4.5"IF B/P 15M STD DUAL w2 1/16" 15M IN

EEN NUMBER		DESCRIPTION	
		VALVE, 3' x 4.5"IF BP 15M STD DUAL w2 1/16 15M INLETS	
WORKING PRESSURE:	TEMPERATURE CLASS:	DRAWN BY:	
15,000 PSI	PU	LMS	
RETAINED FLUIDS:	PR LEVEL:	DATE:	
AA	1	3/20/2015	
WEIGHT:	SHEET:	PART NUMBER:	REV:
923 lbs.	SHEET 1 OF 2	VA0874-S	0



THIS DRAWING IS THE PROPERTY OF DIXIE IRON WORKS, LTD. THE BORROWER AGREES BY RECEIVING THE DRAWING TO RETURN IT UPON REQUEST AND TO NEITHER REPRODUCE COPY OR FURNISH INFORMATION FROM IT TO OTHERS WITHOUT EXPRESSED WRITTEN PERMISSION OF DIXIE IRON WORKS, LTD. ALL ARTICLES MANUFACTURED IN ACCORDANCE WITH THIS DRAWING SHALL BE CONSIDERED DESIGNS OF DIXIE IRON WORKS, LTD. AND MAY NOT BE USED OR SOLD WITHOUT DIXIE IRON WORKS, LTD. WRITTEN PERMISSION.

CHANGE MADE	REVISED BY	DATE
1)		
2)		
3)		
4)		
5)		
6)		
7)		
8)		

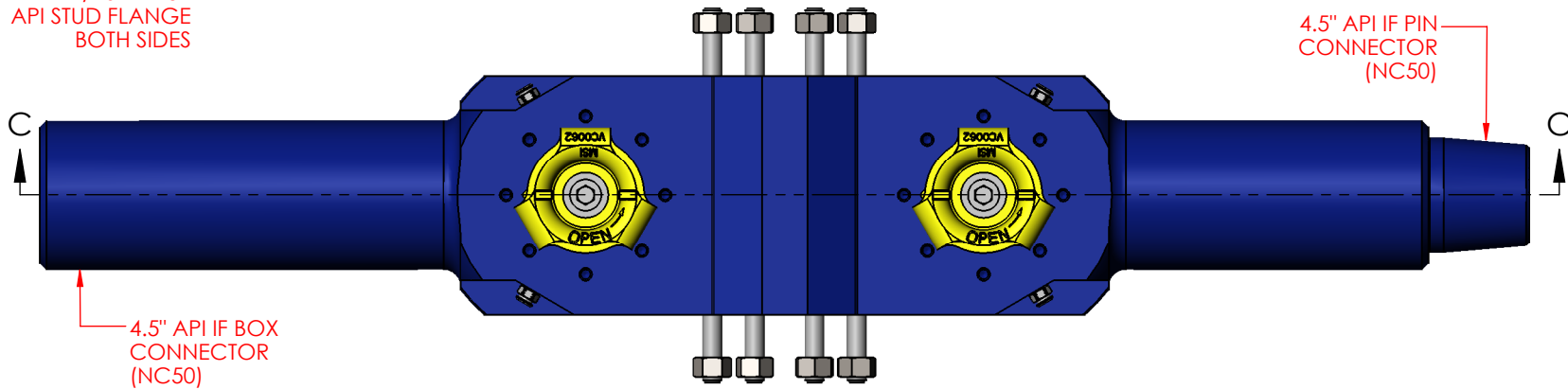
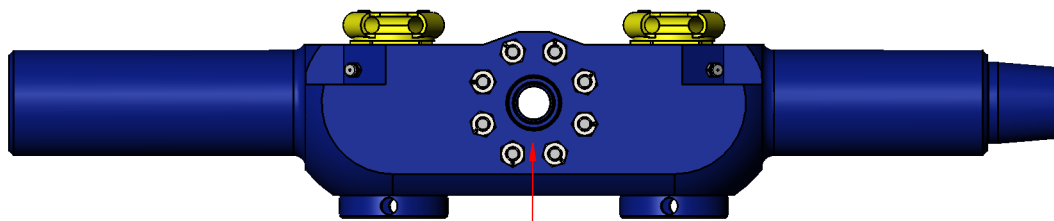
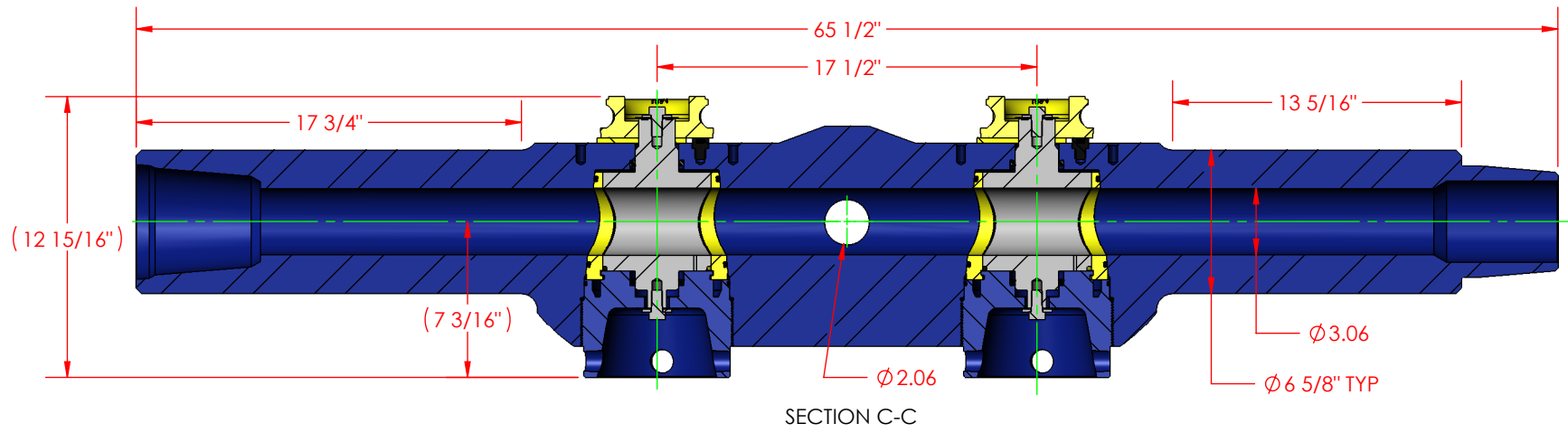

EEN NUMBER		DESCRIPTION	
		VALVE, 3' x 4.5"IF BP 15M STD DUAL w2 1/16 15M INLETS	
WORKING PRESSURE:	TEMPERATURE CLASS:	DRAWN BY:	
15,000 PSI	PU	LMS	
RETAINED FLUIDS:	PR LEVEL:	DATE:	
AA	1	3/20/2015	
WEIGHT:	SHEET:	PART NUMBER:	
923 lbs.	SHEET 2 OF 2	VA0874-S	

CHANGE MADE	REVISED BY	DATE
1)		
2)		
3)		
4)		
5)		
6)		
7)		
8)		

