

NOTE:  
 1) REFER TO AAG-3LT-4000 DRAWING FOR GEAR-OP BOM.  
 2) PLEASE REFER TO OA0015 FOR HARDNESS STENCILING PER API.

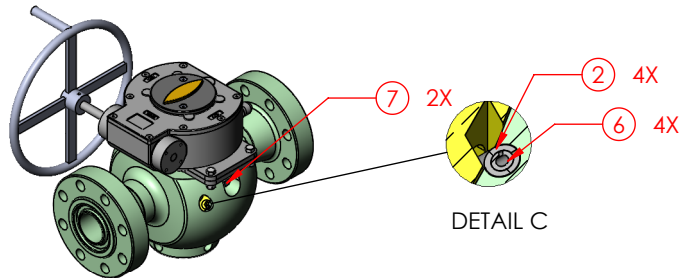

ITEM NO.	QTY.	PART NUMBER	DESCRIPTION
1	1	AAG-3LT-4000	GEAR OP ASSY, PRO GEAR Q4000 3"LT VALVE, FLANGE
2	4	HC0003	ROLL PIN, 5/16" X 3/4" (LARGE)
3	1	HC0006	FLAT WASHER, 1/2" STD
4	1	HC0007	FLAT WASHER, 1/2" FENDER (2"OD)
5	1	HC0009	HEX HD, 1/2"-20 x 1.00"
6	4	HC0011	ROLL PIN, 3/16" X 11/16" (SMALL)
7	2	HC0226-PSL2	GREASE FITTING, 3/4" SAFETAP H2S GBH - PSL2
8	2	OC0002V	O-RING, 3" INSERT H2S (2-343 VITON 90)
9	1	OC0004V	O-RING, 3" ADJ NUT H2S (VITON)
10	1	VC0029-PSL2	ADJUSTING NUT, 3" H2S 15M PSL2
11	1	VC0041S	INSERT SET, 3" H2S (SPLIT)
12	1	VC0070-PSL2	PLUG, 3" H2S (HEX) PSL2
13	2	VC0327	PLUG SEAL, 1.75" - 3" H2S (VITON/BRASS)
14	1	VC0741-PSL2	VLV BODY, 3" x 3 1/16 10M H2S CRA 625

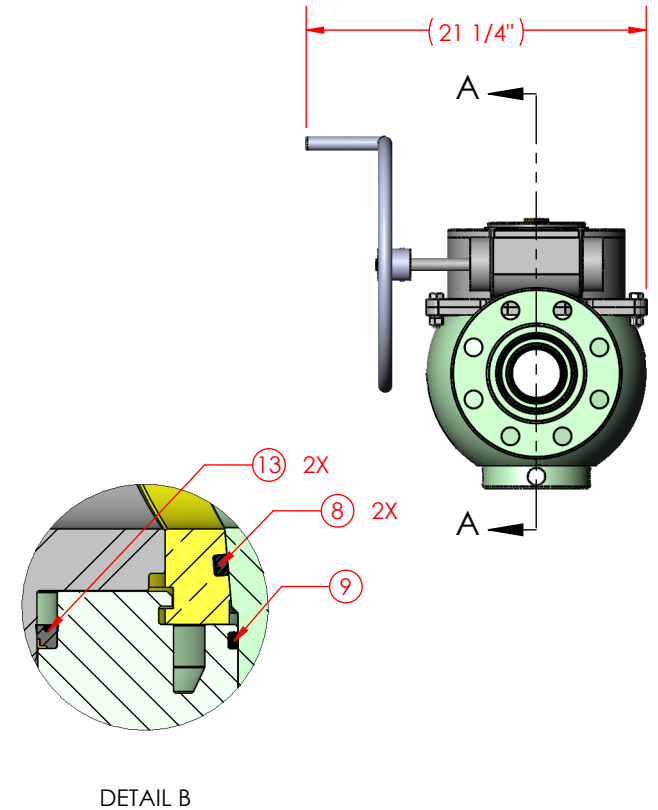
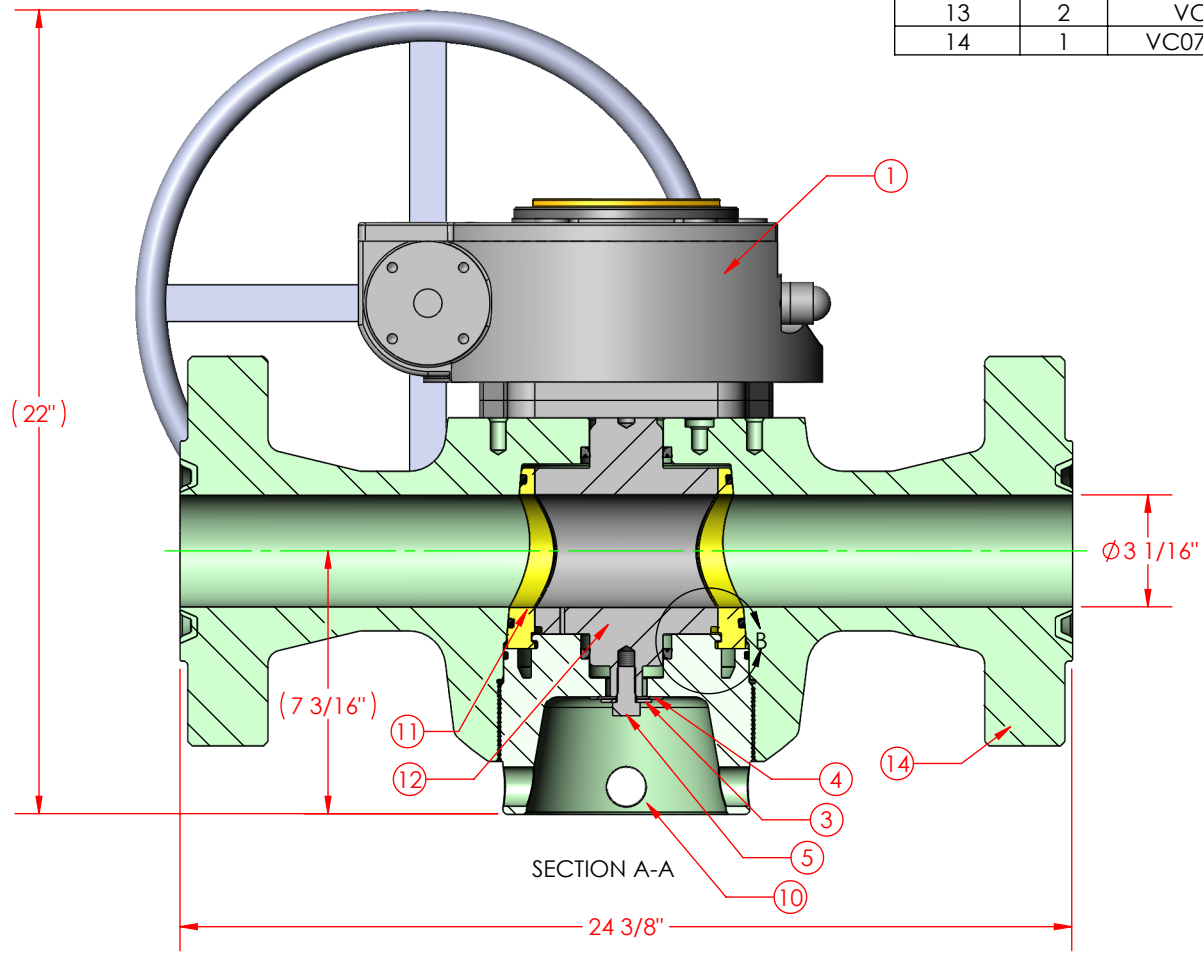

E/CN NUMBER		DESCRIPTION	
		VALVE, 3" x 3 1/16 10M H2S 625 RG, X-TEMP PSL2, API GO	
WORKING PRESSURE:	TEMPERATURE CLASS:	DRAWN BY:	
10,000 PSI	LX	RSE	
RETAINED FLUIDS:	PR LEVEL:	DATE:	
EE-0.5	1	03/06/2015	
WEIGHT:	SHEET:	PART NUMBER:	
481 lbs.	SHEET 1 OF 1	VA0876X-S-PSL2-API	

**MSI**  
 300 WEST MAIN ST.  
 ALICE, TX 78332  
 www.diwmsi.com  
 800.242.0059  
MSI IS A DIVISION OF DIXIE IRON WORKS, LTD.

CHANGE MADE	REVISED BY	DATE
1)		
2)		
3)		
4)		
5)		
6)		
7)		
8)		

THIS DRAWING IS THE PROPERTY OF DIXIE IRON WORKS, LTD. THE BORROWER AGREES BY RECEIVING THE DRAWING TO RETURN IT UPON REQUEST AND TO NEITHER REPRODUCE COPY OR FURNISH INFORMATION FROM IT TO OTHERS WITHOUT EXPRESSED WRITTEN PERMISSION OF DIXIE IRON WORKS, LTD. ALL ARTICLES MANUFACTURED IN ACCORDANCE WITH THIS DRAWING SHALL BE CONSIDERED DESIGNS OF DIXIE IRON WORKS, LTD. AND MAY NOT BE USED OR SOLD WITHOUT DIXIE IRON WORKS, LTD. WRITTEN PERMISSION.