

MSI Pump Order Form

600 HP



PUMP TYPE

- MSI Standard Well Service Pump
- MSI Hybrid™ Well Service Pump

PLUNGER SIZE

Check appropriate box:

Small Fluid End

- 2.75" (15,000 psi max WP)
- 3.00" (14,150 psi max WP)

Large Fluid End

- 3.25" (12,050 psi max WP)
- 3.50" (10,400 psi max WP)
- 4.00" (7,960 psi max WP)
- 4.50" (6,290 psi max WP)

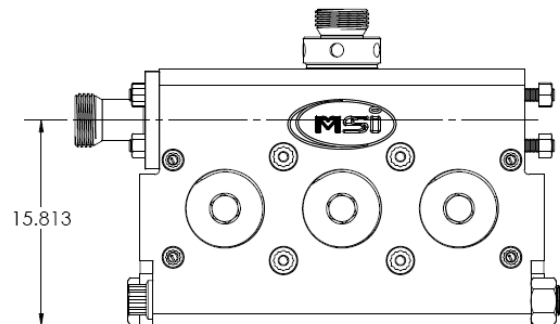
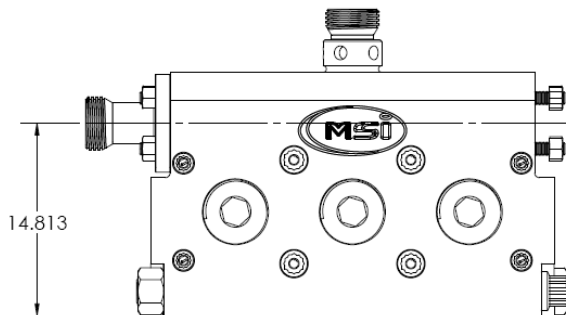

GEARBOX CONFIGURATION

***Note:** These gearboxes will come with a Spicer 1810 series flange as the standard component. Contact MSI for other options.

Check appropriate box: (see diagrams on following three sheets for position number)

- RIGHT
- LEFT

***Note:** Gearbox position is determined from back of Power Frame.

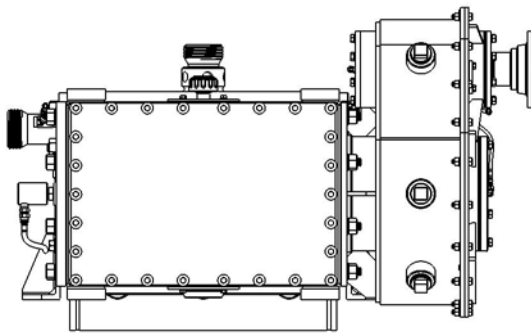

Right Hand

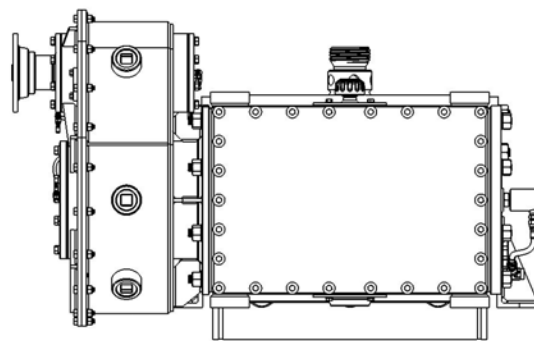

Left Hand

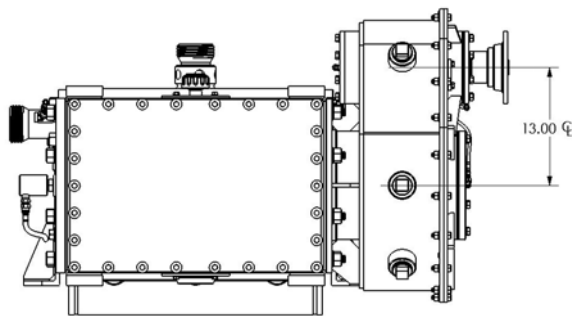

Regular Drive Configuration

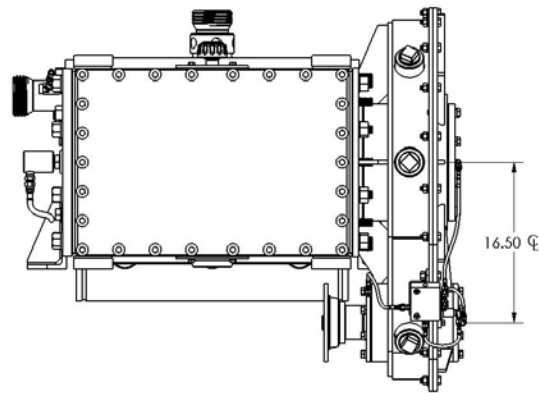

Underdrive Configuration

GEARBOX

Check appropriate box: (see diagrams above)

- REGULAR (4.61:1 Gear Reduction)
- UNDERDRIVE (4.61:1 Gear Reduction)

Please Indicate Your Desired Gear Box Position
 Left Hand Gear Box Positions (Regular Drive)

Position: _____

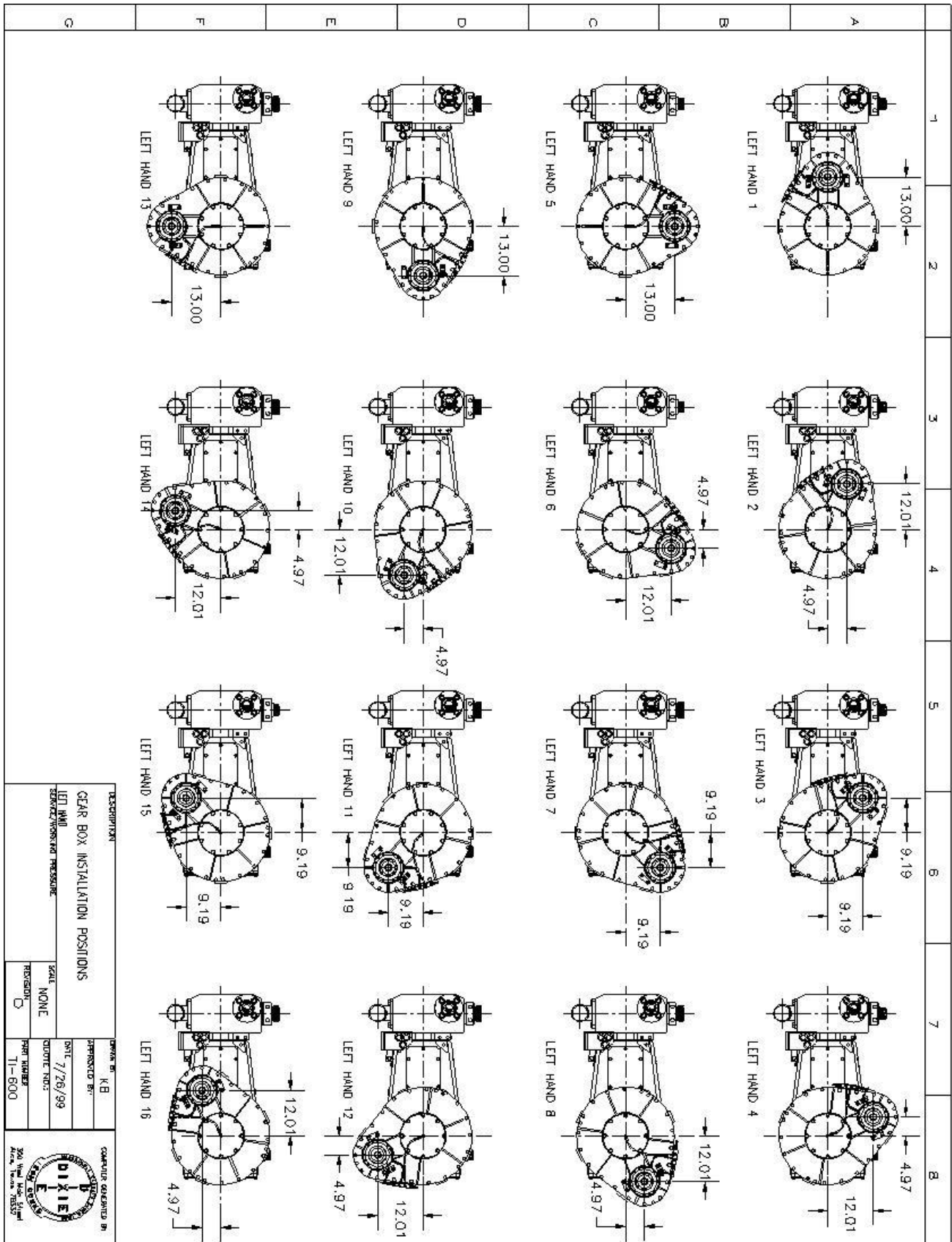

GAGE CONNECTIONS

Select number of gages and positions.

Check appropriate boxes:

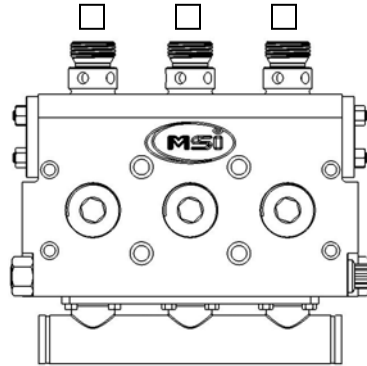

DISCHARGE CONNECTIONS

These connections will be 2"1502 hammer union style

Check appropriate boxes:

MALE

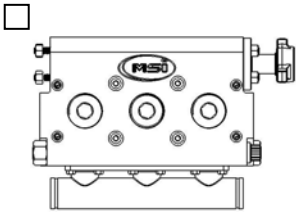

FEMALE

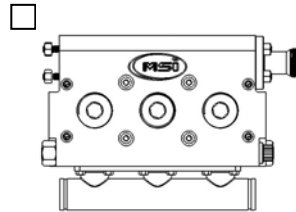

BLANK

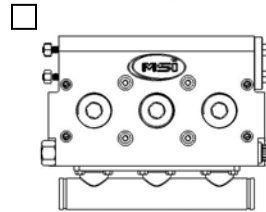

EL

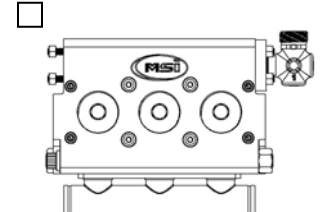

MALE

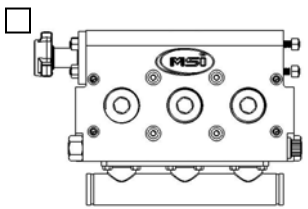

FEMALE

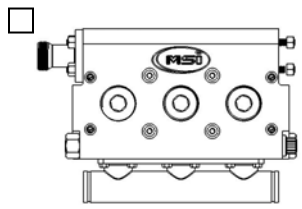

BLANK

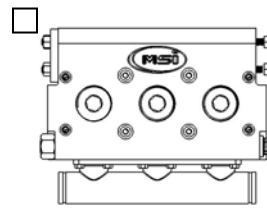

EL

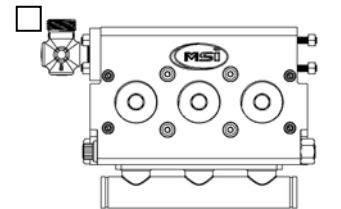

SUCTION MANIFOLD & DRAIN PORTS

Check appropriate box:

The following sizes represent the internal diameter of the Main Tube.

- 4" manifold – Victaulic
- 5" manifold - Victaulic
- 6" manifold - Victaulic

***Note:** Consult factory for prices on other options such as drain ports.

PACKING TYPE

Check appropriate box:

- Standard
- Viton (High Temperature)
- Super Gold (Severe Service- Nitrogen, CO₂)

PAINT COLOR

Check appropriate box:

- GREY PRIMER (Default color)
- CUSTOMER SPECIFIC PAINT*

CODE # _____

*Consult factory for pricing. For special color customer must provide paint codes.

Please understand that these pumps will be assembled to order with the customer specified configurations and special requests. Once the pumps are shipped any alterations to the pumps will be at the customer's expense. These costs will include travel and lodging costs, parts, labor costs, including overtime pay and any incurred cost that would be necessary to comply with the changes desired by the customer.

Customer PO#

Item #

Company Name:

Date:

Signature:



MSI is a division of Dixie Iron Works, Ltd

300 W. Main St.

Alice, Texas 78332, USA

Phone: 800-242-0059

Fax: 361-664-4840

www.diwmsi.com